

Reg No.: _____

Name: _____

APJ ABDUL KALAM TECHNOLOGICAL UNIVERSITY
Fifth Semester B.Tech Degree Examination December 2021 (2019 scheme)

Course Code: MET301

Course Name: MECHANICS OF MACHINERY

Max. Marks: 100

Duration: 3 Hours

PART A

(Answer all questions; each question carries 3 marks)

		Marks
1	What is the difference between a machine and a mechanism? Give examples	3
2	What is kinematic inversion?	3
3	How the direction of coriolis acceleration is obtained?	3
4	Obtain an expression for maximum velocity when a cam follower motion is simple harmonic	3
5	What is interference in gears?	3
6	What are precision points in kinematic synthesis?	3
7	What are the conditions for static equilibrium of a body?	3
8	How does gyroscope helps in the guidance of ships?	3
9	What is the difference between static balancing and dynamic balancing?	3
10	What is partial balancing in reciprocating engines?	3

PART B

(Answer one full question from each module, each question carries 14 marks)

Module -1

- | | | |
|----|--|----|
| 11 | a) Sketch and explain inversions of 4R four bar chain | 10 |
| | b) What are coupler curves? | 4 |
| 12 | Given a four bar mechanism ABCD with following dimensions. Find the velocity of joint C and angular velocities of link CD and BC if the angular velocity of link AB is 10 rad/sec in clockwise direction. Dimensions of various links are AB = 30cm, BC=CD=35cm, AD(fixed) = 60cm, angle BAD = 60°. Use graphical method | 14 |

Module -2

- 13 a) In a slider crank mechanism, crank length is 200mm, connecting rod length is 600mm, angular velocity of crank is 50 rad/sec clockwise and angular acceleration of crank is 800 rad/sec^2 (clockwise), Crank angle when turned from inner dead centre is 120° . Find the angular velocity and angular acceleration of the connecting rod. 10
- b) Obtain an expression for Coriolis acceleration? 4
- 14 The exhaust valve of a diesel engine has a lift of 3cm. It is operated by a cam to give equal uniform acceleration and retardation during rise and return. The rise is 90° of cam rotation followed by dwell during 15° and return during 120° , then dwell during remaining period. Line of stroke of 2cm diameter roller follower is passes through the axis of the cam. Base circle diameter is 6 cm. Draw the displacement diagram and the profile of cam. 14

Module -3

- 15 a) Explain and illustrate law of gearing. 6
- b) A pair of gears having 40 and 30 teeth are of 25° involute form. 8
The addendum length is 5mm and module is 2.5 mm.
If the smaller wheel is driver and rotates at 1500 rpm.
Find the sliding velocity
1) at the point of engagement,
2) at the point of disengagement, and
3) at pitch point.
- 16 a) Design a four-bar mechanism which can co-ordinate the input and output angles as given. 9
Input crank angle $40^\circ, 60^\circ, 90^\circ$: Output crank angle $10^\circ, 40^\circ, 70^\circ$
- b) Explain overlay method of synthesis 5

Module -4

- 17 Find the torque T and its direction of slider crank mechanism shown in the figure below to bring the system in equilibrium, given the forces acting on the slider, $F = 5000\text{N}$ and a force of magnitude 1000N is applied on the connecting rod as shown in figure, the crank angle $\theta = 40^\circ$. Length of the crank = 250mm, connecting rod = 750mm, AC = 250mm 14

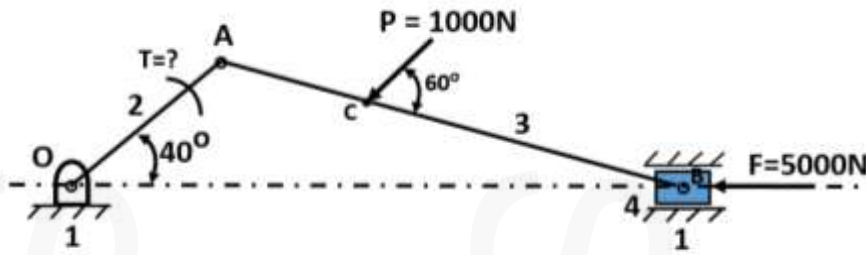

- 18 a) Explain different planes of gyroscope. 4
- b) An aeroplane flying at 240 km/hr turns towards left and complete a quarter circle of 60 m radius. The mass of the rotary engine and the propeller of the plane amounts to 450 kg with a radius of gyration of 320 mm. the engine speed is 2000 rpm, clockwise when viewed from the rear. Determine the gyroscopic couple on the aircraft and state its effects. In what way is the effect changed when (i) the aeroplane turns towards right and (ii) the engine rotates clockwise when viewed from the front (nose end) and aeroplane turns (a) left (b) right? 10

Module -5

- 19 a) What are the conditions for static balancing and dynamic balancing? 4
- b) There are four planes A, B, C and D. The masses attached and radius of rotation respectively are given as follows. $m_1 = 20\text{kg}$, $m_2 = 30\text{kg}$, $m_3 = 24\text{kg}$, $m_4 = 26\text{kg}$, $r_1 = 9\text{cm}$, $r_2 = 7\text{cm}$, $r_3 = 10\text{cm}$, $r_4 = 12\text{cm}$. The plane A is 12cm to the left of reference plane L. Planes B, C and D are 5cm, 30cm and 60cm respectively to the right of plane L. The distance between the reference planes L and M being 50cm. m_2 is at an angle of 45° from m_1 , m_3 is at an angle of 75° from m_2 and m_4 is at 135° from m_3 . Find the magnitude and position of the balance mass required in planes L and M at a radius of 24 cm. 10
- 20 a) Explain the balancing of V-engines. 7
- b) Explain the balancing of a four cylinder in-line engine. 7

Reg No.: _____

Name: _____

APJ ABDUL KALAM TECHNOLOGICAL UNIVERSITY

Fifth Semester B.Tech Degree Regular and Supplementary Examination December 2022 (2019 Scheme)

Course Code: MET 301**Course Name: MECHANICS OF MACHINERY**

Max. Marks: 100

Duration: 3 Hours

PART A*(Answer all questions; each question carries 3 marks)*

- 1 What do you mean degree of freedom (mobility) of a planar mechanism? How is it determined?
- 2 Name any three approximate straight line motion mechanisms
- 3 Define Grashof's law with an example of double crank inversion mechanism
- 4 Obtain the expression for acceleration of the cam follower when it is in simple harmonic motion
- 5 Define pressure angle for (i) Gear and (ii) Cam
- 6 Write three advantages of involute gear tooth profile over cycloid profile
- 7 How do you take into account the friction at sliding pairs for force analysis? Give example.
- 8 What do you mean by spin, precession and gyroscopic plane?
- 9 State the necessary conditions to achieve the static and dynamic balancing of rotating masses
- 10 What do you mean by primary and secondary unbalance in reciprocating engines?

PART B*(Answer one full question from each module, each question carries 14 marks)***Module -1**

- 11 For the four bar linkage given in Fig.1, $O_1O_2 = 420\text{mm}$, $O_1A = 150\text{ mm}$, $AB = 300\text{ mm}$, $O_2B = 250\text{ mm}$, $AC = 230$, $BC = 170\text{ mm}$. $\theta = 60^\circ$. The crank rotates with a uniform angular velocity of 1500 rpm.
 - i. What is the transmission angle? Measure and mark it in the configuration diagram.
 - ii. Using instantaneous centre method, Determine the angular velocities of link 3, link 4, and also the velocities at point A, B and C.

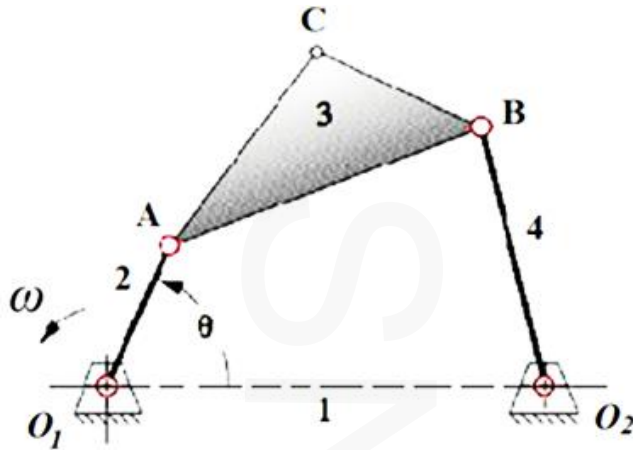

Fig. 1

- 12 In the toggle mechanism shown in Fig. 2, The crank OA rotates at a uniform speed of 200 rpm counter-clockwise (ccw). For the given configuration, $O_1A = 200$ mm, $AB = 400$ mm, $O_2B = 300$ mm, and $BC = 500$ mm. Determine (a) velocity of slider C (b) angular velocities of links AB, O_2B , and BC, (c) rubbing velocities on the pins of 25 mm diameter at A and C. (c) Torque required at crank O_1A for a force of 1000N at C. 14

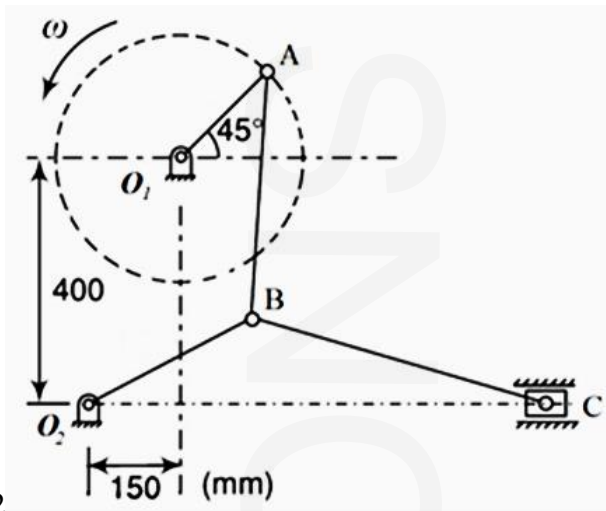

Fig. 2

Module -2

- 13 For the shaper mechanism shown in Fig. 3, the crank OA (link 2) is 75 mm, slotted lever CD is 355 mm and the link DE is 100 mm. The crank rotates at 200 rpm in clockwise direction. When crank makes an angle 30° with horizontal, determine 14
- (i) Velocity of cutting tool attached with the slider link 6
 - (ii) Angular acceleration of slotted lever CD
 - (iii) linear acceleration of slider link

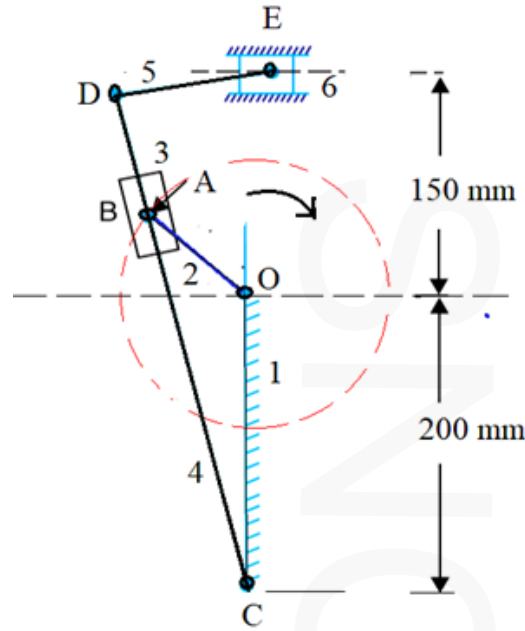

Fig. 3

- 14 A disc cam profile is to be synthesized to give simple harmonic motion (SHM) to a knife edge offset follower during out stroke of 50 mm. The angle of ascent is 120° , dwell 60° , and angle of descent 90° and the follower to dwell for the remaining cam rotation. The minimum radius of cam is 50 mm. (i) Draw the profile of the cam when the knife-edge follower is offset by 20 mm. (ii) Calculate the maximum velocity and acceleration during ascent and descent when the camshaft revolves at 240 rpm and plot the velocity and acceleration diagram

Module -3

- 15 A compound epicyclic gear train is shown in Fig. 4. The gears A, D and E are free to rotate on the axis P. The compound gear B and C rotate together on the axis Q at the end of arm F. All the gears have equal module. The number of teeth on the gears A, B and C are 18, 45 and 21 respectively. The gears D and E are annular gears. The gear A rotates at 120 rpm counter-clockwise and the gear D rotates at 450 rpm clockwise. Find the speed and direction of the arm and the gear E.

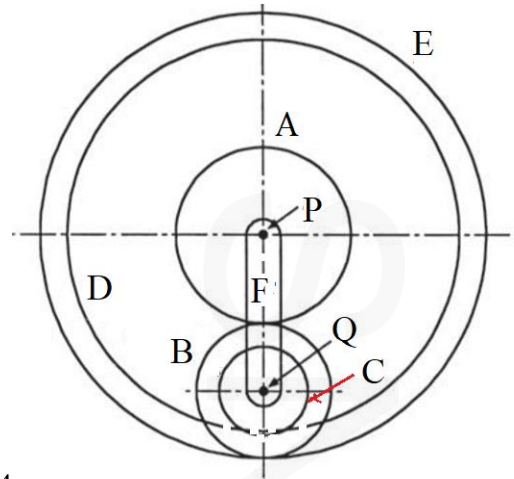

Fig. 4

- 16 a) What is Freudenstein's equation? How do you synthesize a four-link mechanism to coordinate the input and output angles using this equation? Explain. 8
- b) Synthesize a slider-crank mechanism with an eccentricity of 9 mm for the two input positions of input link; $\theta_{12} = 60^\circ$ and output displacement of slider is 16 mm. 6

Module -4

- 17 a) In the slider-crank mechanism shown in Fig. 5, the value of force applied to the slider is 2 Kn. The link dimensions are $AB = 80$ mm, $BC = 240$ mm, and $\theta = 60^\circ$. Determine the forces on various links and driving torque T. 8

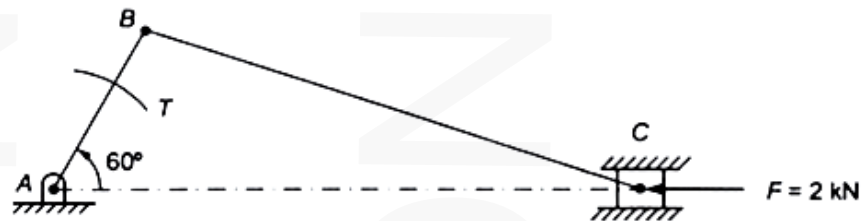

Fig. 5

- b) What is the principle of virtual work? Using this principle establish the relation between torque (T) and slider force (F) for the mechanism shown in Fig. 5. 6
- 18 a) Explain the effect of gyroscopic couple on the motion of an aircraft while taking a turn. 5
- b) A racing car of mass 2000 kg has a wheel base of 2 m and track width of 1 m. The C.G. lies midway between the front and rear axles and is 0.4 m above the ground. The engine of the car has a flywheel rotating in a clockwise direction when seen from the front at 6000 rpm. The moment of inertia of the flywheel is 50 kg-m^2 . If the car takes a curve of 15 m radius towards right, while running at 8

45 km/h, find the reaction between the wheels and the ground considering the gyroscopic effect of the flywheel and centrifugal effect and weight of the car.

Module -5

- 19 A shaft carries four masses A, B, C and D of magnitude 150 kg, 200 kg, 300 kg and 250 kg respectively and revolving at radii 70 mm, 60 mm, 50 mm and 80 mm in planes measured from A at 300 mm, 400 mm and 600 mm. The relative position of masses measured anticlockwise is A to B 45° , B to C 60° and C to D 120° . The balancing masses are to be placed in planes L and M. The distance between the planes containing A and L is 100 mm, between L and M is 400 mm and between M and D is 100 mm. If the balancing masses revolve at a radius of 100 mm, find their magnitudes and angular positions. 14
- 20 The cranks and connecting rods of a 4-cylinder in-line engine running at 1800 rpm are 50 mm and 200 mm long respectively. The cylinders are spaced 150 mm apart. If the cylinders are numbered 1 to 4 in sequence from one end, the cranks appear at intervals of 90° in an end view in the order 1-4-2-3. Reciprocating mass corresponding to each cylinder is 1.5 kg. Determine (a) the unbalanced primary and secondary forces, and (b) the unbalanced primary and secondary couples with reference to central plane of engine. 14
