



Reg. No. :

Name :

SECOND SEMESTER B.TECH. DEGREE EXAMINATION, MAY/JUNE 2016
BE 102 : DESIGN AND ENGINEERING

Max. Marks : 50

Duration : 2 Hours

Instructions: Answer *all* questions; this is an open book examination and the students are **permitted** to use text books, class notes, own notes, earlier assignments; but access to mobile phone and internet is **not allowed**.

PART – A

Each question in Part **A** carries **5** marks.

1. In an ordinary bicycle, name at least 6 parts that are not made of metal. Sketch any one of these parts.
2. How modular design is realized in i) Umbrella and ii) Ink Pen ? Draw the different modules involved in each of these products.
3. Design of a chair with steel tube is shown in Figure. The seat and the back rest are made of wood and are screwed on to the steel frame. Identify the interesting aspect of this design and list the number of different parts used for the chair.



4. Devolve a questionnaire for user centered design for an automobile.
5. Considering the principle of value engineering, design a suitable product for easy cleaning of dust from windows, fans and lamp shades.



6. Sketches of a screw driver and a normal screw head are given below :

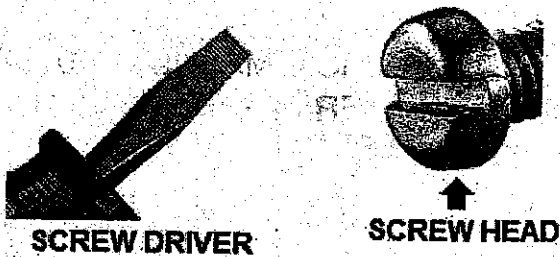

This screw could be tightened or loosened using the screw driver. Now design the head of such a screw that could only be tightened but not loosened by this screw driver.

PART – B

Each question in Part B carries 10 marks.

7. Without using an air-conditioner, blower or exhaust fan, design a natural system of heat removal from the rooms of a building and simultaneous inflow of fresh air from outside into the room. Prepare the necessary sketches and justify your answer.
 8. Develop and sketch anyone design concept of a mechanical system to drive a generator for energy harvesting by exploiting heavy traffic.
-

10202

Reg. No: _____

Name: _____

APJ ABDUL KALAM TECHNOLOGICAL UNIVERSITY
SECOND SEMESTER B. TECH. DEGREE EXAMINATION, JULY 2016

BE 102: Design and Engineering

Duration: **Two hours**Maximum mark: **50**

(Instructions: Answer all questions; this is an open book examination and the students are permitted to use text books, class notes, own notes, earlier assignments; but access to mobile phone and internet is not allowed)

Part A

(Each question in part A carries 5 marks)

1. Four different design of drinking water glasses (i.e., Glass A, B, C, and D) are shown below. Discuss the merits and demerits of each of these four designs.

**a. Glass A****b. Glass B****c. Glass C****d. Glass D**

2. Figure given below shows a screw with a cylindrical head. Modify the design of the screw head so that the screw could be tightened even when it is sunk in the hole as shown.



3. Discuss briefly any five "X" to be considered in the design for "X" of a bag to make it competitive in the market.
4. Identify all the possible customers of a washing machine and prepare questionnaires for each group in order to collect customer requirements.
5. Develop and sketch a new design for a hand held remote control for household equipments which is ergonomically and aesthetically better than conventional one.
6. Design a quick removable handle for the mug shown.



Part B

(Each question in Part B carries 10 marks)

7. A round glass of 600 mm diameter and 6 mm thick is available. This is to be designed as a table supported at three points by a steel tube bent in any convenient way. The height of the table is to be 300 mm and the total length of the tube used should not exceed 1.8 m. The tube should not be cut or joined. Design the bent tube for supporting the table.

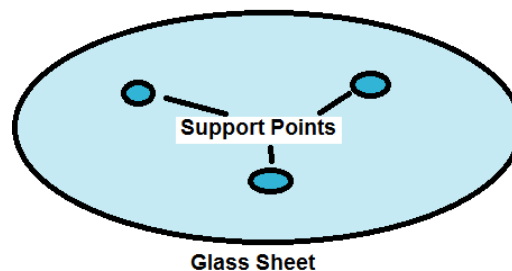

8. Public taps are now fitted with electronic sensors for hands free operation. Sketch the Design concepts of an automatic hands free flushing system for use in toilets. The system should be purely mechanical without any electronic circuits.

10203

Reg. No: _____

Name: _____

APJ ABDUL KALAM TECHNOLOGICAL UNIVERSITY

SECOND SEMESTER B. TECH. DEGREE SPECIAL EXAMINATION, SEPTEMBER 2016

BE102 – DESIGN AND ENGINEERINGDuration: **2 Hours**Maximum Mark: **50**

(Instructions: Answer all questions; this is an open book examination and the students are permitted to use text books, class notes, own notes, earlier assignments; but access to mobile phone and internet is not allowed)

Part A*(Each question in part A carries 5 marks)*

1. Sketch a three legged stool. Why three legged chairs are not used in practice?
2. Compare the following designs of chairs from four specific design attributes.

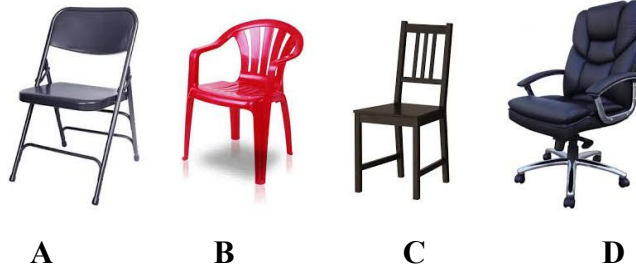

3. In any good design, many standard parts are used.
List at least 10 standard parts that are used in a completed residential house.
4. Two types of electric bulbs that are used normally are shown below.



A has two pins and **B**, a screw to fix it in the socket.

Why the first has two contacts and the second only one, in their design?

5. The sketch below shows a plain saucer for placing the cup. What change can improve the saucer design?



Saucer



Cup

Part B

(Each question in Part B carries 10 marks)

6. People throw bits of paper and plastics on the road. Design a bin for dropping these wastes to be kept at the bus stops. Design needs are as follows:
- i) The bin is theft proof (Cannot be removed from the place easily)
 - ii) Rain water cannot get into the bin even when it is kept under a roof.
 - iii) Wind cannot blow out the contents.
 - iii) Easy to remove the contents of the bin without taking out the bin.
 - iv) Aesthetically designed.
7. A normal water bottle is shown below.



Design a water bottle for kids (Age group: 4 to 6 years) so that they are always happy to use it.
Mention the special features you would incorporate in it to achieve this.
Give a simple sketch of your design.

Reg. No: _____ Name: _____

APJ ABDUL KALAM TECHNOLOGICAL UNIVERSITY
SECOND SEMESTER B. TECH. DEGREE EXAMINATION, JUNE 2017

BE 102: DESIGN AND ENGINEERING

Max. Marks: 50

Duration: 2 Hours

Instructions: *This is an open book examination and the students are permitted to use maximum 4 text books, class notes, own notes, earlier assignments; but access to mobile phone and internet is not allowed. Exchange of text books/notes not permitted.*

PART A

Answer any 6 questions. Five marks each.

1. Give the main objective and constraint for the design of (i) The main entrance door to a house, (ii) The door of a room within the house, (iii) Door to a bathroom inside the house.
2. Two different designs of helmets are shown in the figure 'A' and figure 'B'. Compare their merits and demerits.



Figure 'A'



Figure 'B'

3. Imagine you are the marketing manager of a company which sells bottled water. Design the bottle so that it is as attractive and easy to carry. Also design a trademark for your company and show it on the bottle.
4. Design a book shelf for 'X', where (a) X is ease of assembly, (b) X is ease of disassembly. Justify your answer.
5. Image of a remote control for television developed by a particular company is shown in the figure 'C' below. Prepare a questionnaire to obtain the feedback on the design from the users, so that you can improve upon the design.



Figure 'C'

6. Draw the figure of a smart phone which is both aesthetic and ergonomic.
7. Redesign the assembly given in the following figure based on the principles of design for assembly and manufacture. Sketch the redesigned product.

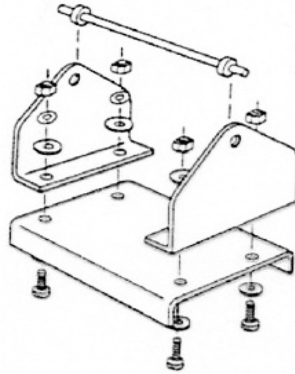

8. Identify all the parts of a ceiling fan. List out the standard parts.

PART B

Answer any 2 questions. Ten marks for each question.

9. Disassemble the book shelf shown in figure 'D'. Use the materials to make another useful product. Show that the wastage of material is minimal.



Figure 'D'

10. Modify a car for the use by a differently able person having only one leg.
11. Design a piping network for reuse of water in a residential building enabling water conservation. Sketch the design.

Reg No.: _____

Name: _____

APJ ABDUL KALAM TECHNOLOGICAL UNIVERSITY
SECOND SEMESTER B.TECH DEGREE EXAMINATION, APRIL 2018

Course Code: BE102

Course Name: DESIGN AND ENGINEERING

Max. Marks: 50

Duration: 2 Hours

Instructions: *This is an open book examination and the students are permitted to use maximum of 4 text books, class notes, own notes, earlier assignments; but access to mobile phone and internet is not allowed. Exchange of text books/notes not permitted. Add Sketches wherever possible.*

PART A

Answer any 6 questions, each carries 5 marks.

- 1 Give the advantages and limitations of these three designs.

Marks
(5)



- 2 Sketch the design of a TV remote showing important buttons. (5)
- 3 State the design objectives, design constraints and design function of the fire extinguisher given below. (5)



- 4 List at least 10 standard parts that are commonly used in a completed residential building. (5)

- 5 Sketch an attachment for a blackboard in a class room for placing the chalks and the remote of the LCD projector securely. (5)
- 6 Identify the design for X of the following roofing materials. Justify your answer. (5)
- i) Tiles ii) Sheets iii) Concrete



- 7 Bring out the features of user centered design and Product centered design with the help of examples for each. (5)
- 8 How modular design is realized in a bicycle? Draw the different modules involved in this product. (5)

PART B

Answer any 2 questions, each carries 10 marks.

- 9 Modify the design of the conventional umbrella so that the below mentioned problems can be solved. (5)
- a) The floor becomes wet once you close the umbrella and put it on the floor after a rain. (5)
- b) Opening of umbrella in a crowd can hurt people. (5)
- 10 Bring out 2 design changes that will increase the value in case of a waste bin. (10)
- 11 Over years, lot of workers have met with accidents while doing electrical maintenance works as part of their job in KSEB. (6)
- a) Prepare a questionnaire to be distributed among the employees of KSEB to find out the main reason behind these accidents. (4)
- b) Assuming that attempting to work on a live line unknowingly is the main reason, suggest a possible solution to avoid such type of accidents. The solution may be explained with the help of layout/ block diagram /sketches.

Reg No.: _____

Name: _____

APJ ABDUL KALAM TECHNOLOGICAL UNIVERSITY
SECOND SEMESTER B.TECH DEGREE EXAMINATION, JULY 2018

Course Code: BE102

Course Name: DESIGN AND ENGINEERING

Max. Marks: 50

Duration: 2 Hours

Instructions: This is an open book examination and the students are permitted to use maximum of 4 text books, class notes, own notes, earlier assignments; but access to mobile phone and internet is not allowed. Exchange of text books/notes not permitted.

PART A

Answer any 6 questions, each carries 5 marks

- 1 In schools, teachers encourage students to bring pencil pouches (Fig. a) rather than pencil boxes (Fig. b). Give any two valid reasons for this. (5)



Fig. a



Fig. b

- 2 Write any five points comparing the designs of the lunch boxes shown in Figs. c to e. (5)



Fig. c



Fig. d



Fig. e

- 3 Identify any 5 DFXs for the design of a laptop. Justify the DFXs proposed by you. (5)
- 4 Disassemble the given wooden stool (Fig. f) and neatly sketch the individual components. Reassemble the components to make a wooden chair. (5)



Fig. f

- 5 Sketch the design of a wall hanging showing any two traditional designs of Kerala. (5)
- 6 Prepare neat sketches of trademarks of any five market leading firms in India. (5)

- 7 Applying the principle of value engineering, design a school bag for students residing in a poor home. Neatly sketch your design and prepare a design description for the same. (5)
- 8 Prepare a feedback questionnaire with minimum ten questions for the newly introduced washing powder in the market. (5)

PART B

Answer any 2 questions, each carries 10 marks

- 9 You are given the following. (i) A 1 mm thick rectangular paper sheet of dimensions 100 cm x 60 cm, (ii) A 2 mm dia. cotton thread 50 cm long (iii) A pair of scissors (iv) A bottle of gum (v) A measuring tape.
- a) Write detailed steps with neat sketches for designing a paper carry bag of dimensions 40 cm x 30 cm x 10 cm (cuboid shape) with maximum functionalities using zero waste concept. (5)
- b) By area computation, prove that the zero-waste concept has been effectively utilised in your design. (5)
- 10 Develop a suitable problem statement and come out with a new design/solution covering the effective waste collection system (food waste, waste paper, plastic waste and human waste from toilets) and safe disposal of the collected waste at major stations without harming the environment. (10)
- 11 Design a manual mango plucker (with height adjusting mechanism) which can be used by a common man to pluck and collect safely the mangoes from the mango tree in his yard.
- a) Prepare a detailed design space to develop the design. (4)
- b) Draw neatly the labelled sketches showing your design. (3)
- c) Give a brief design description highlighting the benefits of your design. (3)

Reg No.: _____

Name: _____

APJ ABDUL KALAM TECHNOLOGICAL UNIVERSITY
SECOND SEMESTER B. TECH DEGREE EXAMINATION (R & S), MAY 2019

Course Code: BE102

Course Name: DESIGN AND ENGINEERING

Max. Marks: 50

Duration: 2 Hours

Instructions: *This is an open book examination and the students are permitted to use maximum of 4 text books, class notes, own notes, earlier assignments; but access to mobile phone and internet is not allowed. Exchange of text books/notes not permitted.*

PART A

Answer any 6 questions, each carries 5 marks

- | | | Marks |
|---|--|-------|
| 1 | List the objectives and constrains for designing a “lunch box” for school students. | (5) |
| 2 | A car manufacturer wants to introduce a new electric car in the market. Prepare a survey questionnaire to collect feedback from the market to get their need and to find out the feasibility of the project. | (5) |
| 3 | Imagine that you own a pizza shop. Prepare a house of quality for your product using the concept of Quality Function Deployment(QFD) | (5) |
| 4 | Prepare the objective tree for the product coconut peeling machine given below. | |

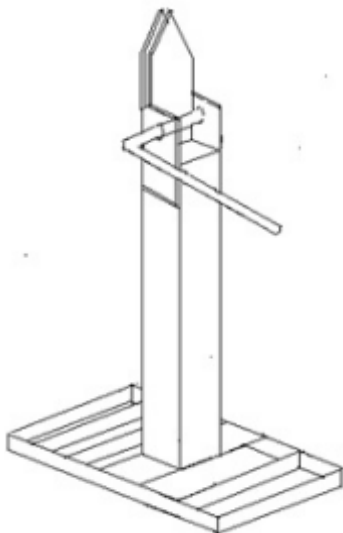

- | | | |
|---|--|-----|
| 5 | What are the factors to be considered for the selection of material for an | (5) |
|---|--|-----|

automobile 'silencer'? justify the answers.

- 6 List the standard items used for the manufacturing of a two wheeler-bike. (5)
- 7 What are the different "intellectual Property rights" (IPR) available for (i) A story written by you, (ii) An article you have invented which you would be marketing. (5)
- 8 What are the aesthetic and ergonomic factors to be considered while designing the driver's seat for a passenger car? (5)

PART B

Answer any two full questions each full question carry 10 marks.

- 9 a) Design a school bag for small school children. (5)
b) Explain any 5 'designs for X' that could be used in the design for school bag. (5)
- 10 a) Design a length adjustable mop to clean ceiling fan. (5)
b) What are the objectives and constraints of that design? (5)
- 11 a) What is meant by modular design? (3)
b) Apply the modular design concept for a product- Bicycle. (7)

Reg No.: _____

Name: _____

APJ ABDUL KALAM TECHNOLOGICAL UNIVERSITY
SECOND SEMESTER B.TECH DEGREE EXAMINATION(S), DECEMBER 2019

Course Code: BE102

Course Name: DESIGN AND ENGINEERING

Max. Marks: 50

Duration: 2 Hours

Instructions: *This is an open book examination and the students are permitted to use maximum of 4 text books, class notes, own notes, earlier assignments; but access to mobile phone and internet is not allowed. Exchange of text books/notes not permitted.*

PART A

Answer any 6 questions, each carries 5 marks

1 Give the main objective and constraints of a train door and a bus door as applicable for aged person (>70 years). (5)

2 Write any five points comparing the designs of food plates shown below



(5)

3 Sketch a traditional steel folding chair and identify its parts. Identify any 3 'Design for X' for the folding chair. (5)

4 Prepare a feedback questionnaire with minimum eight questions for a new school bag introduced in the market. (5)

5 Make a creative design for a water bottle for school kids. (5)

6 Identify all parts of a cycle. List the standard parts. (5)

7 How is modular design realized in a shoe? Draw the different modules involved in the products (5)

8 Considering the principle of value engineering, design a suitable product for easy cleaning of dust from the chalkboards in a classroom. (5)

PART B

Answer any 2 questions, each carries 10 marks

- 9 a) Present the major constraints faced by rescue workers for emergency patient handling during accidents in crowded areas or natural calamities. Present the key objectives of your design. (2)
- b) Design a mobile transport device to carry emergency patients. Give the advantages of your design and make a comparative analysis (8)
- 10 a) Develop a suitable problem statement concerning management of solid waste in hospitals. Present the key objectives of your design. (2)
- b) Propose a solution for effective waste collection (food waste, plastic and medical waste) and safe disposal of the collected waste. Give the advantages of your design and make a comparative analysis (8)
- 11 a) Highlight the major difficulties faced by disabled persons while travelling in trains. (2)
- b) Draw neatly labeled sketches of design modifications that can be done to solve any two such problems. (8)
