

Reg No.: _____

Name: _____

APJ ABDUL KALAM TECHNOLOGICAL UNIVERSITY
Sixth Semester B.Tech Degree Examination June 2022 (2019 Scheme)

Course Code: EET304
Course Name: POWER SYSTEMS II

Max. Marks: 100

Duration: 3 Hours

PART A

Answer all questions, each carries 3 marks.

Marks

- | | | |
|----|--|-----|
| 1 | A 50MVA, 11 kV, three phase synchronous generator was subjected to different types of faults. The fault currents are as follows: LG fault: 4130 A, LL fault 2590 A, 3 Phase fault: 1870 A. The generator neutral is solidly grounded. Find the p.u values of sequence reactances of the generator. | (3) |
| 2 | Draw the zero sequence networks for a) Y-Y b) Y- Δ connected transformers. | (3) |
| 3 | Explain the terms with respect to Gauss Siedel method a) Acceleration factor b) Convergence criteria c) Handling of PV buses. | (3) |
| 4 | State the static load flow problem. | (3) |
| 5 | Differentiate between steady state and transient stability? | (3) |
| 6 | What is critical clearance time and critical clearance angle? What is their significance in stability studies? | (3) |
| 7 | What is SCADA? Give its purpose. | (3) |
| 8 | What is control area and ACE? | (3) |
| 9 | Examine the following: 1) Reasons for maintaining spinning reserve
2) Significance of start-up cost | (3) |
| 10 | Derive the condition for economic dispatch when losses are considered. | (3) |

PART B

Answer one full question from each module, each carries 14 marks.

Module I

- | | | |
|----|---|------|
| 11 | a) Derive the expression for fault current in a line to line fault on unloaded generator. Draw an equivalent network showing the inter connection of networks to simulate a line to line fault. | (10) |
| | b) What are current limiting reactors? Give its function and location. | (4) |

OR

- 12 a) Give reasons a) The neutral grounding impedance Z_n appears as $3Z_n$ in the zero sequence equivalent circuit. (4)
- b) Zero sequence currents cannot flow in the line currents of a delta connected system.
- b) A synchronous generator and a synchronous motor are rated 25 MVA, 11kV and (10) having sub transient reactance of 15% are connected through transformers and a transmission line. The transformers are rated 25MVA, 11/66 kV and 66/11kV respectively with leakage reactance of 10%. The line connecting them has a reactance of 10% on the base of 25MVA, 66kV. The motor is drawing 15 MW at 0.8pf lead and a terminal voltage of 10.6kV when a symmetrical 3phase fault occurs at the motor terminals. Find the sub transient current in the motor, generator and fault by using the internal voltages of the machines.

Module II

- 13 a) Consider the one line diagram of a power system as shown in Fig.1. Line (10) impedances are marked in per unit on a 100MVA base. Obtain the load flow solution using Gauss Siedel technique.

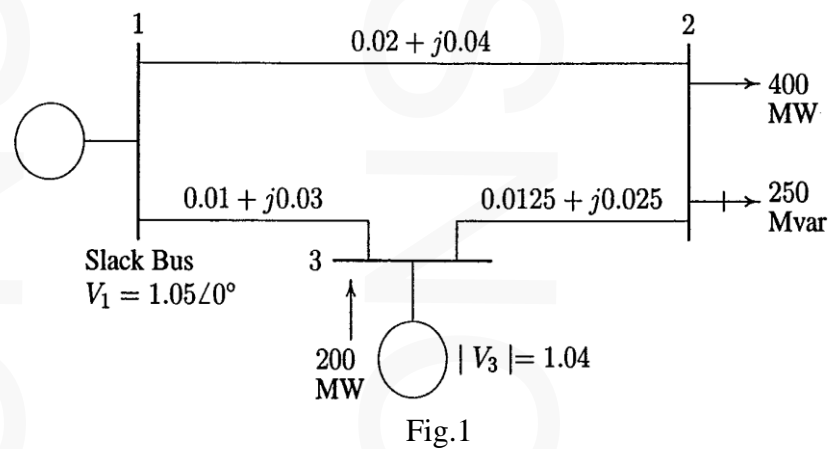

- b) Write a brief note on fast decoupled load flow. (4)

OR

- 14 a) Derive the Newton Raphson power flow analysis algorithm and gives steps for (10) implementation of the algorithm.
- b) What are the operating constraints in load flow analysis? (4)

Module III

- 15 a) Explain the method of solving swing equation by point-by-point method. (8)
- b) A generator having $H=6.0$ MJ/MVA is delivering power of 1p.u. to an infinite (6)

bus through a purely reactive network when the occurrence of a fault reduces the generator output power to zero. The maximum power that could be delivered is 2.5 per unit. When the fault is cleared the original network conditions again exist. Determine the critical clearance angle and time.

OR

- 16 a) Write all methods to improve steady state stability limit of power system. (4)
- b) A three phase fault is applied at the point P as shown in Fig.2. Find the critical clearing angle for clearing the fault with simultaneous opening of the breakers 1 and 2. The reactance values of various components are indicated in the diagram. The generator is delivering 1.0 p.u. power at the instant preceding the fault. (10)

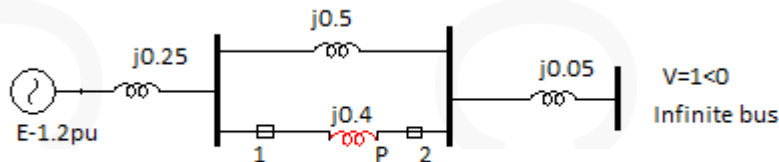

Fig.2

Module IV

- 17 a) Explain the P-f and Q-V control loops of a power system. (4)
- b) Draw the block diagram representation of Load Frequency Control (LFC) of a single area system & explain the steady state stability for free governor operation. (10)

OR

- 18 a) Two generators of rating 100 and 200 MW are operated with a droop characteristic of 6% from no load to full load. Determine the load shared by each generator, if a load of 270 MW is connected across the parallel combination of those generators. (6)
- b) Analyse the dynamic response of frequency for step load change for an isolated power system. (8)

Module V

- 19 a) The cost curves of two plants of a generating system are (10)
- $$\frac{dF_1}{dP_1} = 0.012P_1 + 6.6 \text{ and } \frac{dF_2}{dP_2} = 0.0096P_2 + 6$$
- The loss coefficient for the above system is given as $B_{11} = 5 \times 10^{-3}$, $B_{12} = B_{21} = -0.03 \times 10^{-3}$ and $B_{22} = 8 \times 10^{-3}$ on a base of 100MVA. If plant 1 supplies 200MW and plant 2 supplies 300MW, find the penalty factors

of each plant. Is the present dispatch economical? If not, which plant output must be increased and which one decreased? Give reasons also for the same.

- b) Distinguish between economic dispatch and unit commitment (4)

OR

- 20 a) Define penalty factors and loss coefficients in economic operation of power system. (4)

- b) The fuel inputs per hour of plants 1 & 2 are as given: (10)

$$F_1 = 0.2P_1^2 + 40P_1 + 120 \text{ Rs/hr}$$

$$F_2 = 0.25P_2^2 + 30P_2 + 150 \text{ Rs/hr.}$$

Determine the economic operating schedule and the corresponding cost of generation if the maximum and minimum loading on each unit are 100MW and 25MW and the demand is 180MW and transmission losses are neglected. If the load is equally shared by both the units, determine the savings obtained by loading the units as per the equal incremental production cost.

Reg No.: _____

Name: _____

APJ ABDUL KALAM TECHNOLOGICAL UNIVERSITY

Sixth Semester B.Tech Degree Supplementary Examination May 2023 (2019 Scheme)

Course Code: EET304**Course Name: POWER SYSTEMS II**

Max. Marks: 100

Duration: 3 Hours

PART A*Answer all questions, each carries 3 marks.*

- | | | Mark
s |
|----|---|-----------|
| 1 | A single phase transformer is rated at 110/440V, 2.5 kVA. Leakage reactance measured from LT side of the transformer is 0.06Ω . Determine the leakage reactance in p.u. | (3) |
| 2 | Discuss the effects of faults in power system? Explain the need for fault analysis. | (3) |
| 3 | Explain how buses in a power system are classified? | (3) |
| 4 | Explain the principle of DC load flow. | (3) |
| 5 | Discuss what do you mean by equality and non equality constraints in a power system? | (3) |
| 6 | A 50Hz, 4 pole turbo generator rated 20MVA, 11kV has an inertia constant of $H=9\text{MJ/MVA}$. Find the kinetic energy stored in the rotor at synchronous speed. Find the acceleration if the input less the rotational losses is 26800HP and the electrical power developed is 16MW. | (3) |
| 7 | Discuss the need for maintaining constant frequency in a power system? | (3) |
| 8 | What do you mean by synchronising power coefficient? Explain its significance? | (3) |
| 9 | Define penalty factor. Explain its significance. | (3) |
| 10 | Explain what do you mean by unit commitment. Identify the constraints on unit commitment? | (3) |

PART B*Answer one full question from each module, each carries 14 marks.***Module I**

- 11 a) An alternator and a synchronous motor each rated at 50 MVA, 13.2 kV (10)

having sub transient reactance of 20% are connected through a transmission line of reactance 10% on the base of machine ratings. The motor acts as a load of 30 MW at 0.8 p.f. lead and terminal voltage 12.5 kV when a 3-phase fault takes place at the motor terminals. Determine the sub transient current in the alternator, the motor and the fault.

- b) The line to ground voltages on the high voltage side of a transformer are 100kV, 33kV and 38kV on phase a, b and c respectively. The voltage of phase “a” leads that of “b” by 100° and that lags that of phase “c” by 176.5° . Determine the symmetrical components of voltage. (4)

OR

- 12 a) A 11kV, 10MVA synchronous generator has a sub transient reactance of 15%. Under no load condition, a 3phase fault occurs between the transformer and circuit breaker. Calculate a) initial symmetrical short circuit current b) sustained short circuit current c) maximum dc component of current d) momentary current rating e) current interrupting capacity f) interrupting kVA of the circuit breaker. Assume the circuit breaker is a 2 cycle breaker with voltage rating of 11kV and steady state reactance is 80%. (4)
- b) Derive the expression for fault current for a single line to ground fault on an unloaded generator. Draw an equivalent network showing the inter connection of networks to simulate single line to ground fault (10)

Module II

- 13 a) An incomplete nodal admittance matrix for a 4 bus system is given. Find the missing terms. (7)

$$\begin{bmatrix} 0.7 - j3 & -0.2 + j1 & -0.5 + j2 & y_{14} \\ y_{21} & y_{22} & -0.3 + j2 & -0.5 + j3 \\ y_{31} & y_{32} & y_{33} & -1 + j4 \\ y_{41} & y_{42} & y_{43} & y_{44} \end{bmatrix}$$

- b) What is Jacobian matrix? How the elements of Jacobian matrix are computed? What are the advantages and disadvantages of Newton-Raphson method? (7)

OR

- 14 Obtain the load flow solution at the end of first iteration of the system. The solution is to be obtained for the following cases: (14)

- i) All buses except bus 1 are PQ buses
 ii) Bus 2 is a PV bus whose voltage magnitude is specified as 1.04.
 iii) Bus 2 is a PV bus with voltage magnitude is specified as 1.04 and $0.25 \leq Q_2 \leq 0.8pu$

LINE DATA

Bus Code	R		X
1-2	0.05		0.15
1-3	0.10		0.30
2-3	0.15		0.45
2-4	0.10		0.30
3-4	0.05		0.15
Bus No.	P	Q	V _i
1	-	-	1.04<0
2	0.5	-0.2	-
3	-1.0	0.5	-
4	-0.3	-0.1	-

Module III

- 15 a) Derive the swing equation for a single machine infinite bus system. State clearly the assumptions made. (4)
- b) Figure.1 shows a generator transformer unit feeding an infinite bus bar through a transmission line. At the middle of the transmission line a 3-phase inductor of reactance 0.5 p.u. per phase is connected. The generator emf behind transient reactance is 1.1 p.u. and the voltage of the infinite bus is 1p.u. Find a) transfer reactance and steady state power limit with inductor switch open b) transfer reactance and steady state power limit with inductor switch closed c) transfer reactance and steady state power limit with inductor replaces by a capacitor of same p.u value. (10)

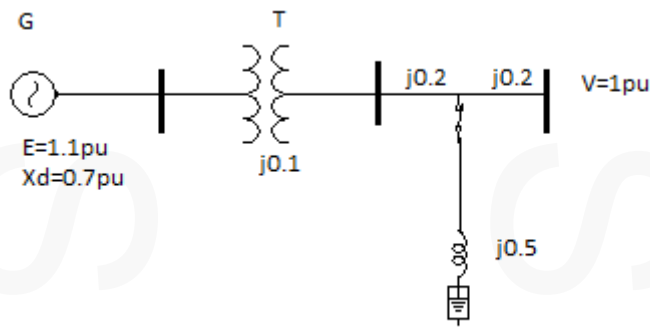

Fig.1

OR

- 16 a) Using equal area criterion, derive an expression for critical clearing angle for a system having a generator feeding an infinite bus through a single circuit line. (10)
- b) A 50 Hz synchronous generator is connected to an infinite bus through a line. The p.u. reactances of generator and the line are $j0.3 \text{ p.u.}$ and $j0.2 \text{ p.u.}$ respectively. The generator no load voltage is 1.1 p.u. and that of infinite bus is 1.0 p.u. The inertia constant of the generator is 3 MW-sec/MVA . Determine the frequency of natural oscillations if the generator is loaded to 60% of its maximum power transfer capacity and small perturbation in power is given. (4)

Module IV

- 17 a) A 125 MVA turbo-alternator operator on full load operates at 50 Hz. A load of 50 MW is suddenly reduced on the machine. The steam valves to the turbine commence to close after 0.5 s due to the time lag in the governor system. Assuming the inertia to be constant, $H = 6 \text{ kW/kVA}$ of generator capacity, calculate the change in frequency that occurs in this time. (4)
- b) Derive the block diagram of a two-area system. (10)

OR

- 18 a) Draw a neat block diagram of a typical speed-governing system and derive its block diagram representation. (10)
- b) State why P-f and Q-V loops can be treated as non-interactive. (4)

Module V

- 19 a) A constant load of 400 MW is supplied by two 210-MW generators 1 and 2, (10)

for which the fuel cost characteristics are given as

$$C_1 = 0.05 P_{G1}^2 + 20 P_{G1} + 30 \text{ Rs/hr}$$

$$C_2 = 0.06 P_{G2}^2 + 15 P_{G2} + 40 \text{ Rs/hr}$$

The real-power generations of units P_{G1} and P_{G2} are in MW. Determine: The most economical load sharing between the generators. 2) The saving in Rs./day thereby obtained compared to the equal load sharing between two generators.

- b) Derive the condition for economic dispatch when transmission losses are neglected. (4)

OR

- 20 a) Derive the expression for transmission losses as a function of power generation. (4)

- b) A two-bus system is shown in Fig. 2. If a load of 125 MW is transmitted from plant 1 to the load, a loss of 15.625 MW is incurred. Determine the generation schedule and the load demand if the cost of received power is Rs. 24/MWhr. Solve the problem using coordination equations and the penalty factor method approach. The incremental production costs of the plants are: (10)

$$\frac{dF_1}{dP_1} = 0.025P_1 + 15$$

$$\frac{dF_2}{dP_2} = 0.05P_2 + 20$$



Fig.2

Reg No.: _____

Name: _____

APJ ABDUL KALAM TECHNOLOGICAL UNIVERSITY

B.Tech Degree S6 (R, S) / S4 (PT) (R, S) Examination June 2023 (2019 Scheme)

Course Code: EET304**Course Name: POWER SYSTEMS II**

Max. Marks: 100

Duration: 3 Hours

PART A*Answer all questions, each carries 3 marks.*

Marks

- 1 Two generators rated 10MVA, 13.2kV and 15MVA, 13.2 kV are connected in parallel to a bus bar. They feed two motors of input 8MVA and 12MVA. The operating voltages of the motors are 12.5kV. Assuming base quantities as 50MVA and 13.8 kV, draw the reactance diagram. The percentage reactance of the generator is 15% and for motors is 20%. (3)
- 2 Discuss the effect of faults in a power system? Explain what do you mean by a symmetrical fault. (3)
- 3 Explain how are buses classified. (3)
- 4 A power system network has 100 buses. The Y-Bus matrix is 90 % sparse. Determine the number of transmission lines in the system. (3)
- 5 A 50 Hz synchronous generator is connected to an infinite bus through a line. The p.u. reactances of generator and the line are $j0.3$ p.u. and $j0.3$ p.u. respectively. The generator no load voltage is 1.2 p.u. and that of infinite bus is 1.0 p.u. The inertia constant of the generator is 3 MW-sec/MVA. Determine the frequency of natural oscillations if the generator is loaded 75% of its maximum power transfer capacity and small perturbation in power is given. (3)
- 6 Define synchronizing coefficient. For what value of synchronizing coefficient the system remains stable. (3)
- 7 Why should the system frequency be maintained constant? (3)
- 8 Differentiate between ACE in a single-area system and a two-area system. (3)
- 9 Discuss about thermal unit constraints in unit commitment problem? (3)
- 10 Explain how economic dispatch can be done when transmission losses are considered. (3)

PART B

Answer one full question from each module, each carries 14 marks.

Module I

- 11 a) Derive the expression for fault current and draw the interconnection of sequence networks for line to ground fault on the terminals of an unloaded generator. (10)
- b) In a 3phase unsymmetrical system, the line currents flowing towards a delta connected load are $I_a=10\angle-45^\circ$ and $I_b=10\angle90^\circ$. Find the symmetrical components of line currents. (4)

OR

- 12 a) A synchronous generator and motor are rated 25MVA, 11 kV, having sub transient reactances of 15% are connected through transformers and a transmission line. The transformers are rated 25MVA, 11/66kV and 66/11kV with leakage reactance of 10% each. The line connecting them has a reactance of 10% on the base of 25MVA, 66kV. The motor is drawing 15MW at 0.8 p.f. leading and a terminal voltage of 10.6kV when a symmetrical three phase fault occurs at the motor terminals. Find the sub transient currents in the generator, motor and fault using the internal voltages of the machines. (10)
- b) Explain how circuit breaker ratings are chosen. (4)

Module II

- 13 a) For the system shown, obtain the power flow solution by Fast Decoupled Load flow. The voltage at bus 1 is adjusted to 1.05 p.u. Voltage magnitude at bus 3 is fixed at 1.04 p.u. with real power generation of 200MW. A load consisting of 400MW and 250MVAR is taken from bus 2. Line impedances are marked in per unit on a 100MVA base and line susceptances are neglected. (10)

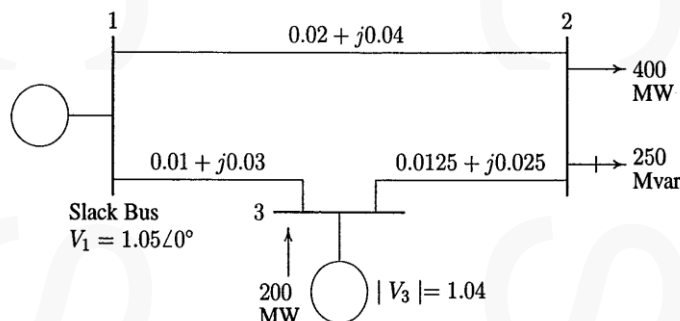

- b) What is a Jacobian Matrix? How are the elements of the Jacobian matrix computed? (4)

OR

- 14 a) The following is the system data for load flow solution. The line admittances are given in the following table. (10)

Bus code	Admittance
1-2	2-j8
1-3	1-j4
2-3	0.666-j2.664
2-4	1-j4
3-4	2-j8

The schedule of active and reactive powers are:

Bus Code	P	Q	V	Remarks
1	-	-	1.06	Slack
2	0.5	0.2	-	PQ Bus
3	0.4	0.3	-	PQ Bus
4	0.3	0.1	-	PQ Bus

Determine the voltages at the end of first iteration. Take $\alpha=1.6$.

- b) Compare Gauss-Siedel and Newton Raphson load flow methods. (4)

Module III

- 15 a) State and explain equal area criterion. How do you apply equal area criterion to find the maximum additional load that can be suddenly added? (8)
- b) A 200 MVA, 11 KV 50Hz 4 pole turbo alternator has an inertia constant of 6MJ/MVA. Find i) stored energy in the rotor at synchronous speed. The machine is operating at a load of 120MW. When load increases to 160MW, ii) find the rotor acceleration, neglecting losses. (6)

OR

- 16 a) The single-line diagram of the figure shows a power system, where power is fed through parallel transmission lines to a large metropolitan system considered as an infinite bus. The machine is delivering 1.0 per unit power and both the terminal voltage and infinite-bus voltage are both 1.0 per unit. The reactances of all components are shown on the diagram. a) Determine the power angle equation for the given system. (8)
- b) If a three phase fault occurs at point P, find the new power angle equation. Plot the two curves.

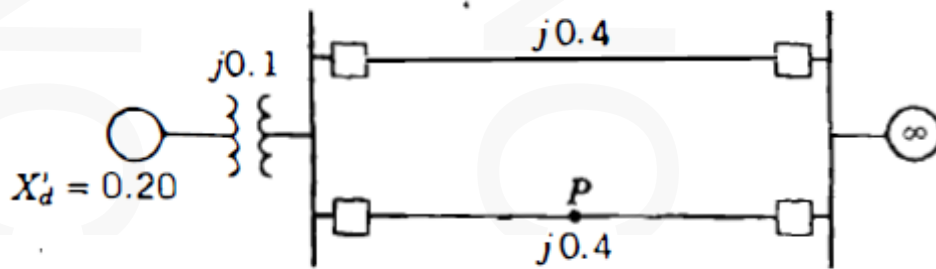

- b) What is critical clearing angle and time? Obtain expressions for the same. (6)

Module IV

- 17 a) Derive from fundamentals, the complete block diagram of load frequency control of an isolated power system. (10)
- b) A 125 MVA turbo-alternator on full load operates at 50 Hz. A load of 50 MW is suddenly reduced on the machine. The steam valves to the turbine commence to close after 0.5 s due to the time lag in the governor system. Assuming the inertia to be constant, $H = 6$ kW/s per kVA of generator capacity, calculate the change in frequency that occurs in this time. (4)

OR

- 18 a) Explain about proportional plus integral LFC with a block diagram. (10)
- b) A 500-MW generator has a speed regulation of 4%. If the frequency drops by 0.12 Hz with an unchanged reference, determine the increase in turbine power. And also find by how much the reference power setting should be changed if the turbine power remains unchanged. (4)

Module V

- 19 a) Determine the saving in fuel cost in Rs./hr for the economic distribution of a (10)

total load of 225 MW between the two units with IFCs:

$$\frac{dF_1}{dP_1} = 0.075P_1 + 15$$

$$\frac{dF_2}{dP_2} = 0.085P_2 + 12.$$

Compare with equal distribution of the same total load.

- b) What are B-coefficients? Write the expression for transmission loss in terms of B - coefficients when there are three generating stations. (4)

OR

- 20 a) A two bus system is shown in figure. If a load of 120MW is transmitted from plant 1 to a load a loss of 16.425MW is incurred. Determine the optimal scheduling of plants and the load demand if the cost of received power is Rs. 26/MWh. (10)

. The incremental production costs of the plants are

$$\frac{\partial F_1}{\partial P_1} = 0.015P_1^2 + 18P_1 + 20$$

$$\frac{\partial F_2}{\partial P_2} = 0.03P_1^2 + 33P_2 + 40$$



- b) What do you mean by spinning reserve? Why the spinning reserve must be maintained. (4)
