

Reg No.: _____

Name: _____

APJ ABDUL KALAM TECHNOLOGICAL UNIVERSITY
FIFTH SEMESTER B.TECH DEGREE EXAMINATION, DECEMBER 2017

Course Code: CE303

Course Name: STRUCTURAL ANALYSIS –II (CE)

Max. Marks: 100

Duration: 3 Hours

PART A

Answer any two full questions, each carries 15 marks.

Marks

- 1 Derive the three-moment theorem equations for general loading. (15)
- 2 a) Analyse the continuous beam shown in Fig. 1, using three-moment theorem (7)
 (Assume EI as constant throughout the beam). Draw BMD.

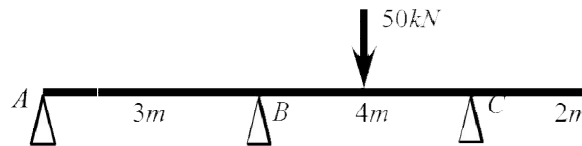

Fig. 1

- b) Find the bending moments at B and C of the continuous beam shown in Fig. 1, using slope deflection method (Assume EI as constant throughout the beam). (8)
- 3 Analyse the 2D frame shown in Fig. 2, using slope deflection method. Draw BMD.

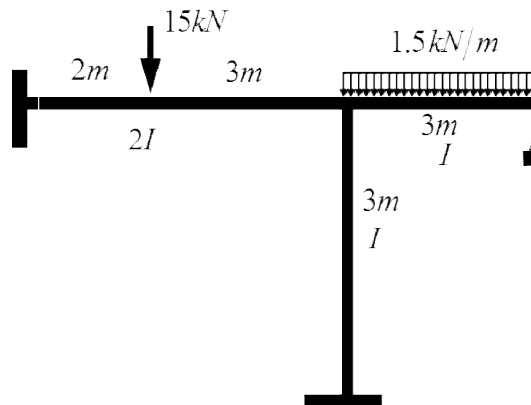

Fig. 2

(15)

PART B

Answer any two full questions, each carries 15 marks.

- 4 Analyse the 2D frame shown in Fig. 2, using moment distribution method. Draw BMD. (15)
- 5 a) Derive expressions for stiffness at the near-end and carry over factor for a beam (8)

with hinged far-end.

- b) Differentiate between moment distribution method and Kani's method. (7)
- 6 Analyse the 2D frameshown in Fig. 3, using Kani's method. Draw BMD. (15)

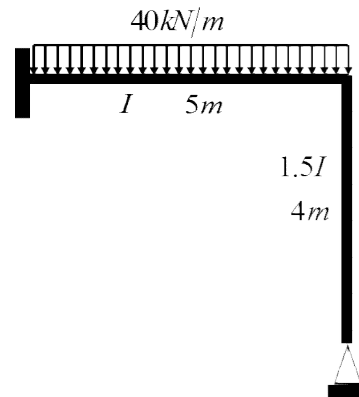

Fig.3

(15)

PART C

Answer any two full questions, each carries 20 marks.

- 7 Analyse and draw bending moment and twisting moment diagrams for a beam semi-circular in plan, and supported at three equally spaced hinges. The radius of the beam in plan is 3m, and it carries a UDL of 10kN/m. (20)
- 8 a) Derive expressions for shear force, bending moment and torsion of a beam with the shape of a quadrant of a circle in plan, fixed at one end and free at the other, with a point load at the free end. (10)
- b) Find out shape factor for an isosceles triangular section of base b and height h . (10)
- 9 Find the plastic moment capacity required for the beam shown in Fig. 4. Assume uniform section throughout. (20)

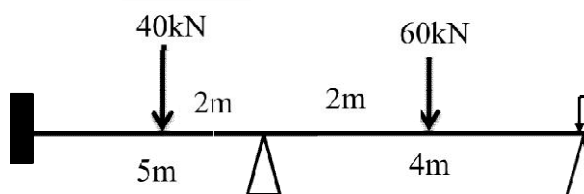

Fig. 4

(20)

Reg No.: _____

Name: _____

APJ ABDUL KALAM TECHNOLOGICAL UNIVERSITY
FIFTH SEMESTER B.TECH DEGREE EXAMINATION, APRIL 2018

Course Code: CE303

Course Name: STRUCTURAL ANALYSIS -II

Max. Marks: 100

Duration: 3 Hours

PART A

Answer any two full questions, each carries 15 marks

Marks

- 1 a) Explain the term static indeterminacy with two examples. (5)
 b) Analyse the continuous beam shown in fig.1 by Three moment equation and draw the BMD and SFD. Given $EI = 3200 \text{ kNm}^2$. (10)

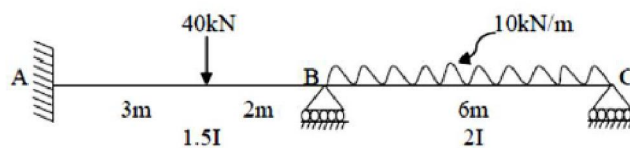

Fig.1

- 2 a) Explain how the effect of settlement of support is taken care of while analyzing the continuous beams using slope deflection method. (5)
 b) Analyse the continuous beam shown in fig.2 by slope deflection method and draw the BMD. (10)

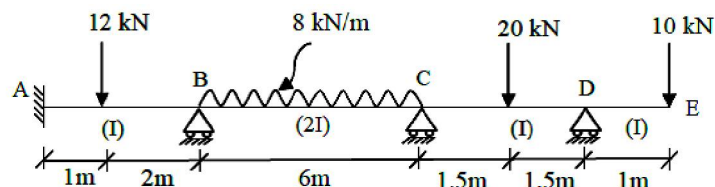

Fig.2

- 3 a) Derive the Clapeyron's theorem of three moments. (7)
 b) Analyse the frame shown in fig.3 by slope deflection method and draw the BMD. (8)
 Moment of inertia for all the members are same. $EI = 3000 \text{ kNm}^2$.

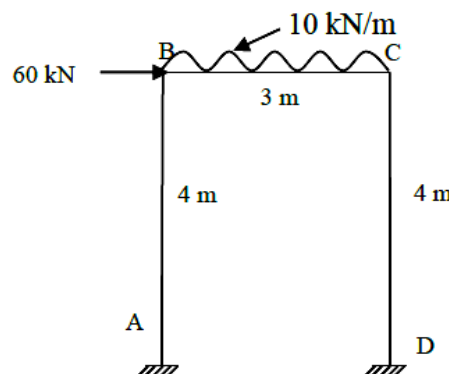

Fig.3

PART B

Answer any two full questions, each carries 15 marks

- 4 a) Define the following terms: (5)
 i) Carry over moment ii) Carry over factor iii) distribution factor
 b) Analyse the rigid frame shown in fig.4 by moment distribution method and draw the BMD. (10)

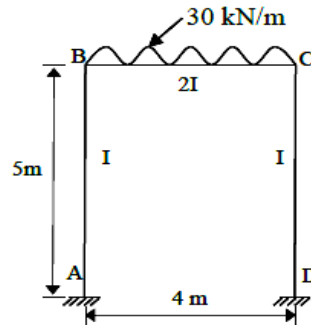

Fig.4

- 5 a) Differentiate between rotational factor and rotation contributions. (5)
 b) Analyse the continuous beam shown in fig.5 by Kani's method and draw the BMD. (10)

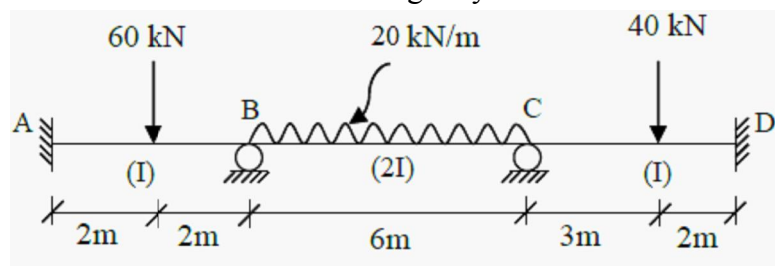

Fig.5

- 6 a) Describe the procedure for analysis of indeterminate structures by Kani's method. (5)
 b) List out the situations that causes sway in portal frames with neat sketches. (4)
 c) Explain the procedure to be followed for the analysis of rigid frames with sway by method of moment distribution. (6)

PART C

Answer any two full questions, each carries 20 marks

- 7 a) List out the circumstances where curved beams are provided. (4)
 b) Discuss the different types of forces developed in a curved beam. (6)
 c) Derive an expression for deflection at the free end of a quarter circle beam of radius R carrying a vertical load P at its free end. Sketch the shear force, bending moment and its torsional moment diagrams. Assume flexural rigidity (EI) = torsional rigidity (GJ). (10)
- 8 a) What are the assumptions made in theory of plastic analysis? (5)
 b) Derive an expression for collapse load for a simply supported beam of span L carrying a concentrated load of W at centre by static and kinematic method. (5)
 c) Calculate the plastic moment carrying capacity required for the continuous beam with the working loads as shown in fig.6. Take load factor = 1.5 (10)

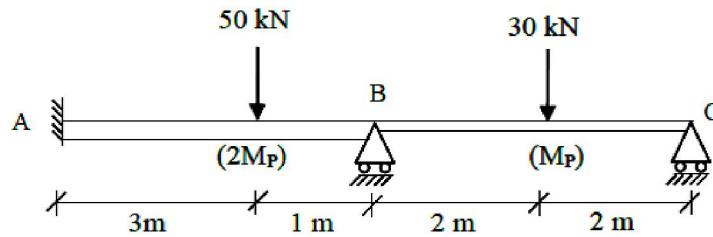

Fig.6

- 9 a) Define shape factor. Also derive the shape factor for a rectangular section with breadth 'b' and depth 'd'. (6)
- b) Define the following terms: (4)
- i) Load factor ii) Plastic modulus iii) Plastic hinge
- c) A beam shown in fig.7 is semi-circular in plan supported on three equally spaced supports. The beam carries a uniformly distributed vertical load of w /unit of the circular length. Analyse the beam and sketch the bending moment and twisting moment diagrams. (10)

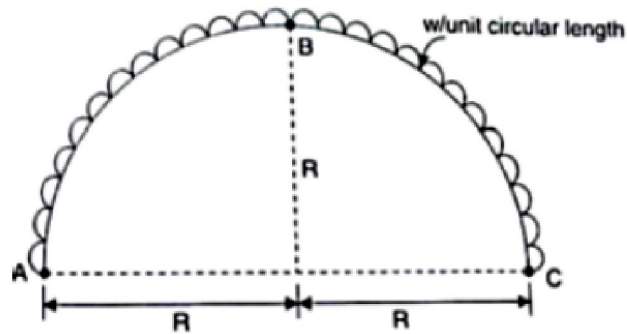

Fig.7

Reg No: _____

Name: _____

APJ ABDUL KALAM TECHNOLOGICAL UNIVERSITY
FIFTH SEMESTER B.TECH DEGREE EXAMINATION, DECEMBER 2018

Course Code: CE303
Course Name: STRUCTURAL ANALYSIS -11

Max. Marks: 100

Duration: 3 Hours

PART A

Answer any two full questions, each carries 15 marks.

Marks

- 1 Analyse the three-span continuous beam ABCD, with overhang DE, for the loading, end support conditions, spans and flexural rigidity as shown in Fig. 1, by applying the theorem of three moments. Draw the BMD and SFD. (15)

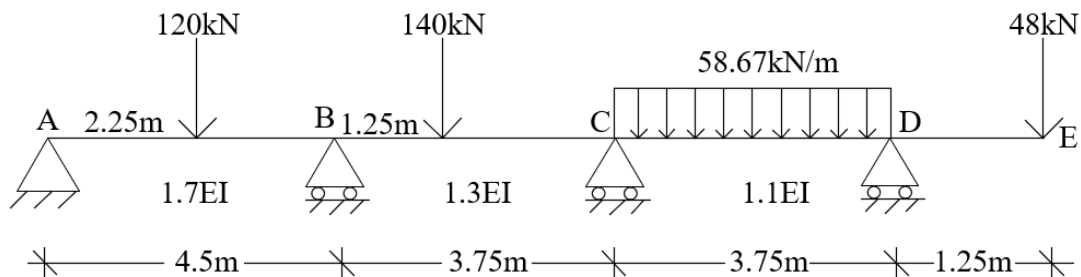

Fig. 1

- 2 a) Differentiate between force and displacement methods of analyses. Give one example for each case. (3)
- b) Determine the moments at A, B and C using slope deflection method for the frame shown in Fig 2. Draw the BMD. (12)

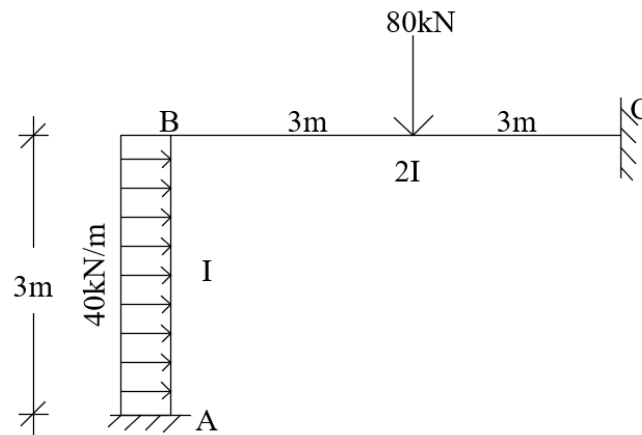

Fig. 2

- 3 a) What are the reasons for sway in frames? (4)
b) Set up the slope deflection equations for a beam considering support settlement. (4)
c) Write down the analysis procedure of a continuous beam ABC fixed at the ends A and C by three moment equation. Roller support is provided at B. Moment of inertia and span length of AB and BC are I_1, L_1 and I_2, L_2 . Span AB carries UDL and span BC supports a central concentrated load. (7)

PART B

Answer any two full questions, each carries 15 marks.

- 4 Analyse the continuous beam shown in Fig. 1 by moment distribution method. Draw BMD and SFD (15)
5 Analyse the frame in Fig. 2 by Kani's method. Draw BMD. (15)
6 a) Formulate Kani's analysis procedure using a prismatic beam element AB having length l and flexural rigidity EI (10)
b) Differentiate distribution factor and rotation factor in structural analysis. (5)

PART C

Answer any two full questions, each carries 20 marks.

- 7 a) Explain the following terms. (8)
(i) Plastic hinge (ii) Load factor (iii) Shape factor (iv) Plastic Moment
b) Determine the shape factor of a circular section with diameter D . (6)
c) Locate the plastic hinges in a propped cantilever beam carrying UDL. (6)
8 a) Determine the collapse load for the fixed beam AB of span L . At point C, $0.2L$ distance from the left support A, there is a concentrated load of $1.25 W$ and another concentrated load of W is acting at point D which is $0.25L$ from the support B. The plastic moment of resistance of the beam is M_p . (10)
b) Determine the deflection at free end of a beam in the shape of a quadrant of a circle in plan, fixed at one end and free at the other, with a point load at the free end. (10)
9 Determine the expression for bending moment and twisting moment for circular ring beam supported by a no: of columns placed at regular intervals. (20)

Reg No.: _____

Name: _____

APJ ABDUL KALAM TECHNOLOGICAL UNIVERSITY
FIFTH SEMESTER B.TECH DEGREE EXAMINATION(S), MAY 2019

Course Code: CE303

Course Name: STRUCTURAL ANALYSIS -11

Max. Marks: 100

Duration: 3 Hours

PART A

Answer any two full questions, each carries 15 marks.

Marks

- 1 a) Derive the equation for Clapeyron's three moment theorem considering unequal settlement of supports, different span lengths and different moment of inertia for adjacent spans. (10)
- b) Brief the sway analysis procedure for analysis of portal frames using slope deflection method. (5)
- 2 The ends A and C of a two-span continuous beam ABC are fixed and B is provided with roller support. Span AB is 4m long and carries a UDL of 15kN/m. BC has a span of 2m and carries a concentrated load of 80kN at 1.5m from the fixed end C. Analyse the beam ABC by the theorem of three moments and plot the BMD and SFD. Assume EI constant. (15)
- 3 a) Set up the slope deflection equations for a beam considering support settlement. (3)
- b) Using the slope deflection method, determine the moments at supports for the beam shown in Fig. 1 if the support B sinks by 10mm. Given $I=1.32 \times 10^8 \text{ mm}^4$ and $E=2 \times 10^5 \text{ N/mm}^2$. (12)

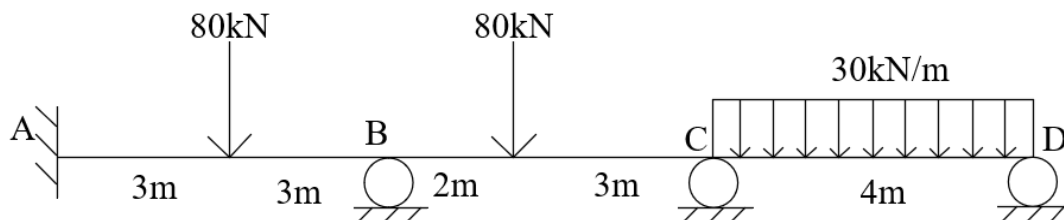

Fig. 1

PART B

Answer any two full questions, each carries 15 marks.

- 4 Analyse the rigid frame ABCD by moment distribution method. Ends A and D are fixed. AB and CD are vertical members with moment of inertia I and length 4m . The horizontal member BC with moment of inertia $2I$ is 6m long and acted upon by a concentrated load of 100kN at 2m from B. (15)
- 5 Analyse the three-span continuous beam ABCD by Kani's method and draw BMD and SFD. Left end support A is fixed and all other supports are roller supports. Span AB= 6m , BC= 5m and CD= 4m . Span AB carries a central concentrated load of 80kN , BC carries a concentrated load of 80 kN at 2m from B and CD carries a UDL of 30kN/m . EI is constant. (15)
- 6 a) Determine the moments at A, B, C of frame shown in Fig. 2 using Kani's method and plot BMD. (7)

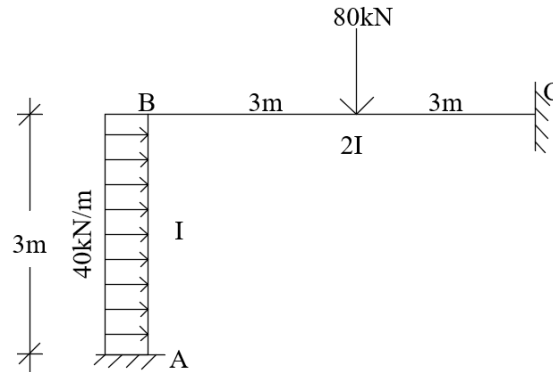

Fig. 2

- b) Analyse the continuous beam shown in Fig. 3 by moment distribution method (8)

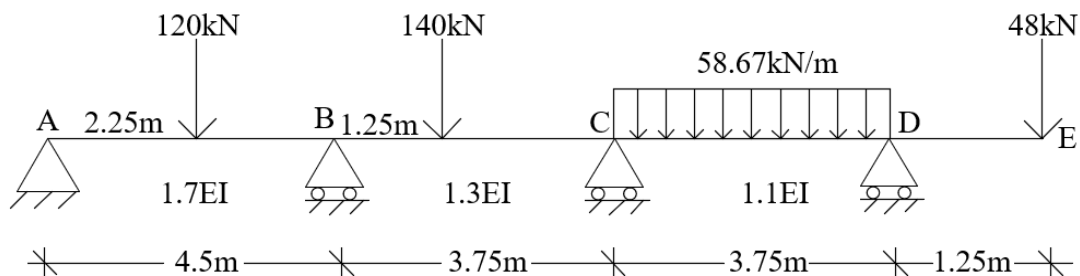

Fig. 3

PART C

Answer any two full questions, each carries 20 marks.

- 7 a) Determine the shape factor of T- Section with flange width 120 mm. Depth of web is 110 mm. Thickness of flange and web is 10 mm. If the value of yield stress is 250 N/mm^2 , find the plastic moment capacity of the section (10)
- b) Determine the deflection at free end of a beam in the shape of a quadrant of a circle in plan, fixed at one end and free at the other, with a point load at the free end. (10)
- 8 Derive the expressions for bending moment and twisting moment at any section in a circular ring beam supported by a no: of columns placed at regular intervals. (20)
- 9 Determine the value of collapse load for the portal frame shown in Fig 4. All the members have the same plastic moment of resistance. (20)

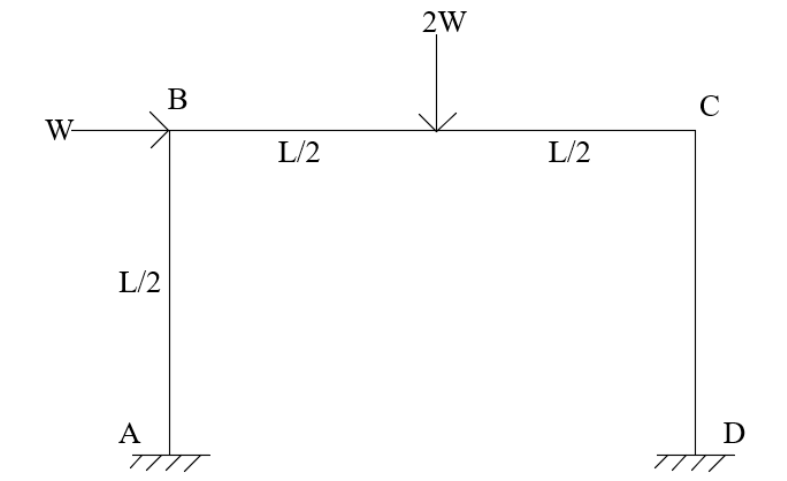

Fig 4

Reg No.: _____

Name: _____

APJ ABDUL KALAM TECHNOLOGICAL UNIVERSITY
FIFTH SEMESTER B.TECH DEGREE EXAMINATION(R&S), DECEMBER 2019

Course Code: CE303
Course Name: STRUCTURAL ANALYSIS -11

Max. Marks: 100

Duration: 3 Hours

PART A

Answer any two full questions, each carries 15 marks.

Marks

- 1 Analyse the continuous beam shown in figure by three moment theorem. Relative I values are marked below each span. Draw BMD and SFD. (15)

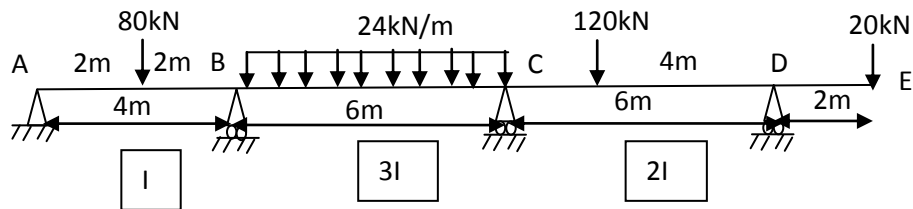

- 2 a) What are the causes of sway in portal frames? (3)
 b) Using slope deflection method, analyse the continuous beam and draw BMD and SFD. EI is constant. (12)

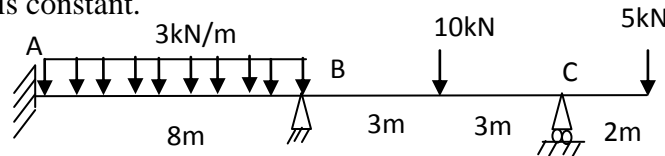

- 3 Analyse the portal frame by slope deflection method and draw shear force diagram and bending moment diagram. Relative I values are marked for each member. (15)

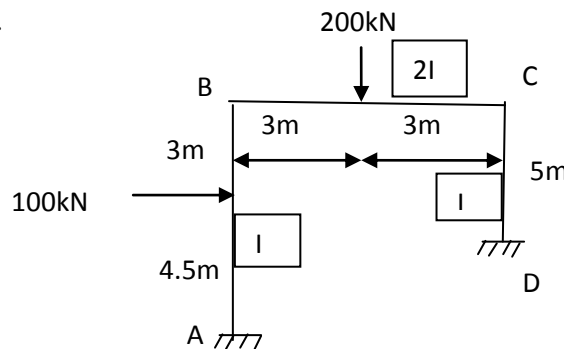

PART B

Answer any two full questions, each carries 15 marks.

- 4 a) Explain distribution factor and carryover factor (3)
- b) Using moment distribution method, determine the support moments in the continuous beam ABCD. Due to external loading, support B settles by 5mm and C by 10mm. Assume EI as $80,000\text{kN-m}^2$. Relative EI values are marked below each span. (12)
- C due to external loading, support B settles by 5mm and C by 10mm. Assume EI as $80,000\text{kN-m}^2$. Relative EI values are marked below each span.

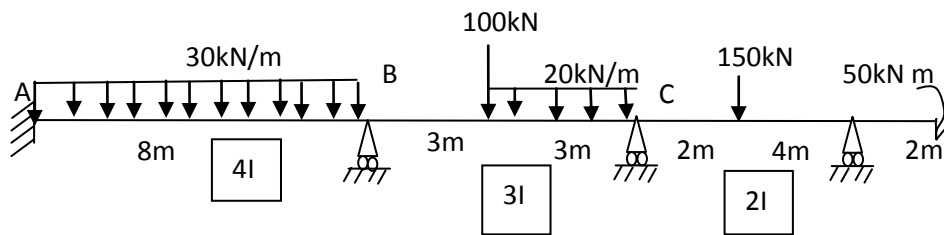

- 5 Analyse the portal frame by Kani's method and draw BMD. (15)

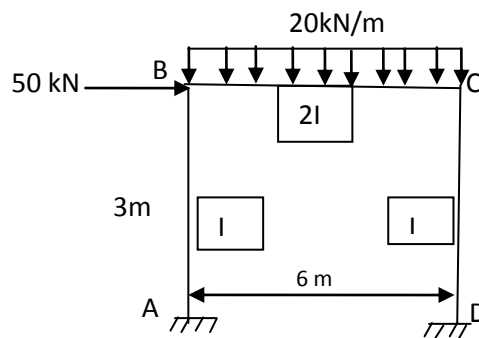

- 6 a) Distinguish between rotation factor and displacement factor (3)
- b) Using Kani's method, find out the end moments of the members of the portal frame. Relative EI values are indicated along the members. (12)

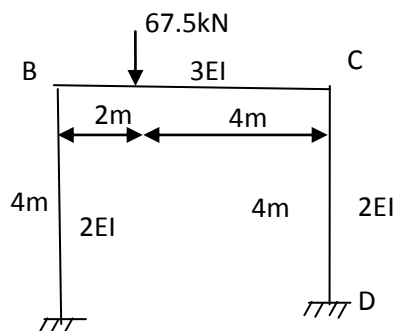

PART C

Answer any two full questions, each carries 20 marks.

- 7 a) A curved beam in the form of a quadrant of a circle of radius 3m and having a uniform cross-section is in a horizontal plane. It is fixed at A and free at B and carries a vertical concentrated load 30kN at the free end B. Draw shear force, bending moment and twisting moment diagrams. (6)
- b) Find the bending moment at midspan of a semicircular beam uniformly loaded over the whole beam by a vertical load of intensity 10kN/m and simply supported at the ends and at midspan. Find also the bending moment and twisting moment at quarter points in the beam. Radius of the beam = 5m. (14)
- 8 a) Explain plastic section modulus (2)
- b) State the three theorems of plastic collapse (5)
- c) Determine the collapse load (W_c) for the fixed beam by kinematic method (13)

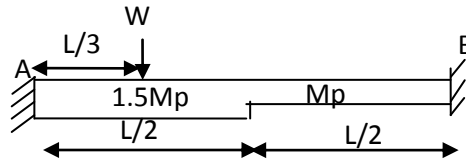

- 9 a) Determine the shape factor for a triangular section of base b and height h (5)
- b) (15)

Find the value of M_p for the frame of uniform section under the applied factored loads.

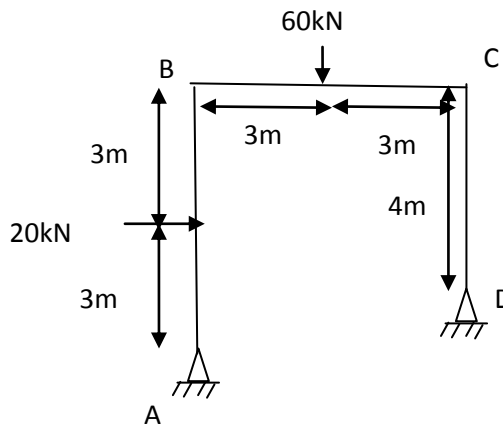

Reg No.: _____

Name: _____

APJ ABDUL KALAM TECHNOLOGICAL UNIVERSITY

Fifth semester B.Tech degree examinations (S) September 2020

Course Code: CE303**Course Name: STRUCTURAL ANALYSIS -II**

Max. Marks: 100

Duration: 3 Hours

PART A*Answer any two full questions, each carries 15 marks.*

Marks

- 1 Analyse the continuous beam given in Fig.1 using Three moment equation. Also draw SFD and BMD. (15)

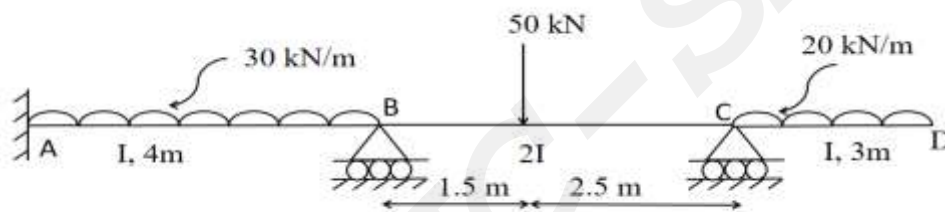

Fig.1

- 2 a) Write three moment equation and mention the terms involved it. (4)
- b) How will you account for support settlement in the analysis of continuous beams by three moment equation? (3)
- c) Analyse the continuous beam given in Fig.1 by Slope deflection method and draw BMD. (8)
- 3 Analyse the portal frame given in Fig.2 using Slope deflection method and draw BMD. (15)

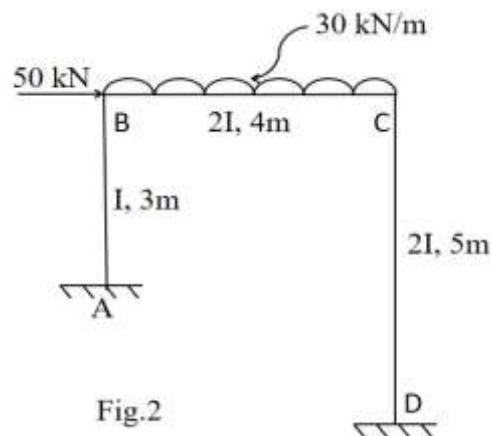

Fig.2

PART B

Answer any two full questions, each carries 15 marks.

- 4 a) Differentiate between absolute stiffness and relative stiffness. (5)
- b) Analyse the continuous beam given in Fig.3 by Moment distribution method and draw BMD. (10)

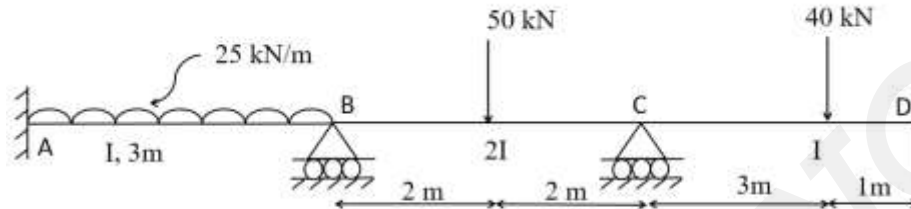

Fig.3

- 5 a) With the help of suitable figures, list the conditions under which a portal frame may sway laterally. (5)
- b) Write down the analysis procedure of a continuous beam by Kani's method. (5)
- c) What do you understand by support settlement and how does it affect the final moments in a continuous beam? (5)
- 6 Analyse the portal frame in Fig.4 by Kani's method and draw BMD. (15)

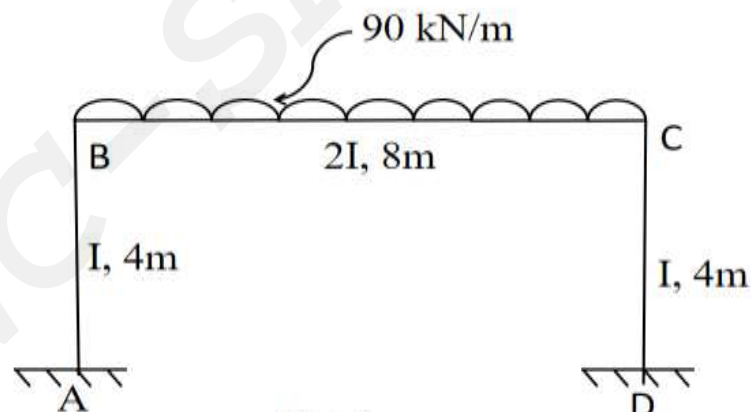

Fig.4

PART C

Answer any two full questions, each carries 20 marks.

- 7 Analyse and draw bending moment and twisting moment diagrams for a beam semi circular in plan, and supported on three equally spaced hinges. The radius of the beam is 3.5 m and it carries a udl of 20 kN/m. (20)
- 8 a) Derive the expression for deflection at free end of a beam in the shape of a quadrant of a circle in pla, fixed at one end, with a point load at the free end. (8)

- b) Calculate the plastic moment capacity of the portal frame shown in Fig.5 assuming (12)
same plastic moment for all members.

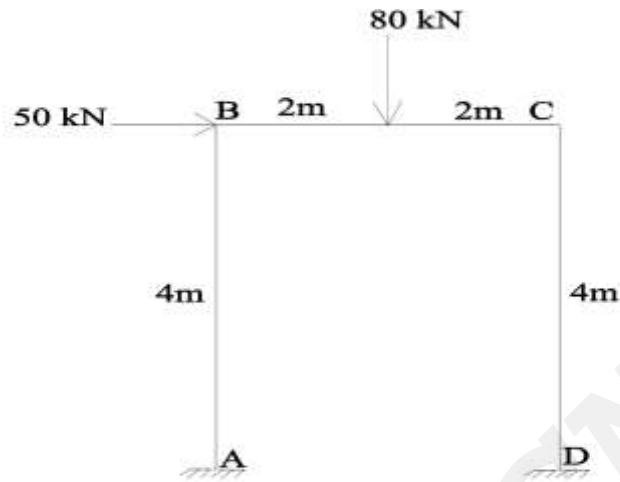

Fig.5

- 9 a) List the assumptions in Plastic theory. (5)
b) Define shape factor and derive the same for a circular section of diameter D. (7)
c) Calculate the plastic moment capacity of the continuous beam shown in Fig.6. (8)

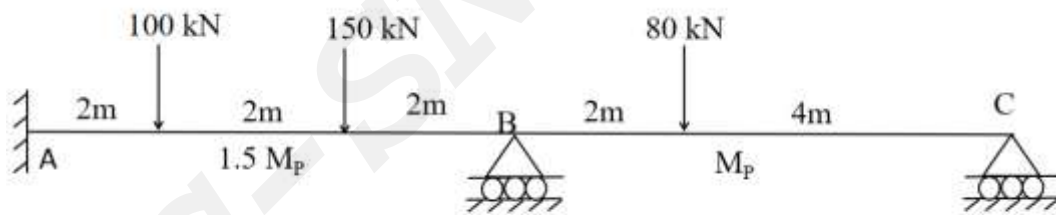

Fig.6
