

11004

Reg. No.: _____

Name: _____

FIRST SEMESTER B.TECH DEGREE EXAMINATION, JANUARY 2016

Course Code: BE110

Course Name: ENGINEERING GRAPHICS

Max. Marks: 50

Duration: 2 Hours

PART A

Answer ANY ONE question. (1x 11= 11 Marks)

1. The ends of a line AB are 50 mm and 20 mm above HP. The length of its elevation is 70 mm and its VT is 10 mm above HP. The line is inclined at 40° to VP. Find its true length and true inclination with HP. Also locate its traces.
2. The midpoint of a line AB measuring 80 mm is 50 mm above HP and 30 mm in front of VP. The line is inclined at 45° to HP and 30° to VP. Draw the projections and find the length of plan and elevation.

PART B

Answer any 3 Questions (3 x 13 = 39 Marks)

3. A square prism of base side 30 mm and length 50 mm has a base edge on VP, axis inclined at 35° to VP and the resting base edge is inclined at 45° to HP. Draw the projections of the solid.
4. A hemisphere of diameter 80 mm is resting on the ground with its flat surface facing upwards. A square pyramid having side of base 40 mm and axis 60 mm is resting on its base centrally on top of the hemisphere. Draw the isometric projection of the combination of solids.
5. A right circular cone of base diameter 60 mm is cut by a section plane so that the true shape of the section is a parabola of maximum double ordinate 50 mm and vertex of the parabola is 70 mm from this ordinate. Draw the front view, sectional top view and true shape of the section.
6. A cube of 25 mm side is placed vertically with its top face on an auxiliary ground plane, which is at a height of 45 mm above the horizon plane. The nearest vertical edge of the cube touches the picture plane and the adjacent square faces of this edge are equally inclined to the picture plane. Draw the perspective view of the cube, if the station point is 70 mm in front of the picture plane and lies in a central plane which is 30 mm to the right side of the centre of the cube.



Reg. No. :

Name :

SECOND SEMESTER B.TECH. DEGREE EXAMINATION, MAY/JUNE 2016

Course Code : BE110

Course Name : ENGINEERING GRAPHICS

Max. Marks : 50

Duration : 2 Hours

PART - A

Answer any one question :

(1×11=11 Marks)

1. An 80 mm long line PQ has its end P on the HP and 15 mm in front of the V.P. The line is inclined at 30° to the HP and its top view is inclined at 60° to the reference line. Draw the projections of line PQ and determine true angle of inclination with the VP.
2. Find graphically the length of the largest rod that can be kept inside a hollow cuboid (rectangular prism) of 60 mm x 40 mm x 30 mm.

PART - B

Answer any three questions :

(3×13=39 Marks)

3. A square pyramid of base side 30 mm and axis length 60 mm is suspended by means of a string from one of its base corners with its axis parallel to VP. Draw its projections.
4. Isometric view of a cylindrical block is shown in Figure 1. Draw the front view, top view and side view from left. Take the arrow direction F as the front side.

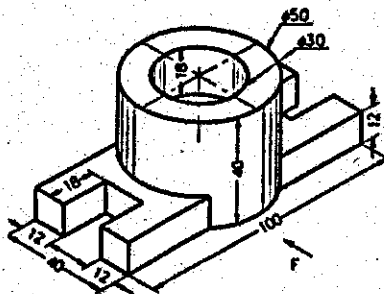

Figure 1



5. A cylinder of diameter 50 mm and length of the axis 65 mm rests on its base with the axis perpendicular to the HP. It is cut by the cutting plane perpendicular to the VP, inclined at 45° to the HP and passing through a point on axis 25 mm from the top. Draw the front view, the sectional top view and the development of the lateral surface of the cylinder.

 6. Draw the perspective projection of a pentagonal prism of side 25 mm and length 50 mm, lying on one of its rectangular faces on the ground plane and one pentagonal face touching the picture plane. The station point is 55 mm in front of the picture plane and lies in the central plane which is 75 mm to the left of the centre of the prism. Station point is 30 mm above the ground plane.
-

11007

Reg. No.:.....

Name:.....

FIRST/SECOND SEMESTER B.TECH DEGREE EXAMINATION, JULY 2016**Course Code: BE110****Course Name: ENGINEERING GRAPHICS**

Max. Marks: 50

Duration: 2 Hours

PART A*Answer ANY ONE question (1x 11=11 Marks)*

1. Three wires AB, CD and EF are tied at points A, C, E on a 14 m long vertical pole at heights 12 m, 10 m and 8 m, respectively, from the ground. The lower ends of the wires are tied to hooks at points B, D and F on the ground level, all of which lie at the corners of an equilateral triangle of 7.5 m side. If the pole is situated at the centre of the triangle, determine the length of each rope and its inclination with the ground.
2. The front and top views of a straight line PQ measures 50 mm and 65 mm, respectively. The point P is on the HP and 20 mm in front of the VP. The front view of the line is inclined at 45° to the reference line. Determine the true length of PQ and its true inclinations with the reference planes. Also, locate the traces.

PART B*Answer ANY THREE Questions (3 x 13 = 39 Marks)*

3. A pentagonal prism of 25 mm base side and 50 mm axis length is resting on the H.P. on one of its base corners with its axis inclined at 40° to the H.P. and parallel to the V.P. Draw its projection when the base sides containing the resting corner are equally inclined to the H.P.
4. A hexagonal prism having base with a 30mm side and 40mm height is surmounted by a hemisphere such that the hemisphere is touching all the edges of the top face. Draw the isometric view of the arrangement.
5. A cone with a 50 mm base diameter and a 70 mm long axis, rests on its base on the H.P. Draw the sectional top view and the development of its lateral surface when it is cut by an inclined plane bisecting the axis and inclined at 45° to the H. P.
6. A square prism, having base with a 50mm side, is resting on its base on the H. P. It is completely penetrated by another square prism having base with a 40 mm side, such that the axes of both the prisms intersect each other at right angles and faces of both the prisms are equally inclined to the V.P. Draw the projections of the combination and show the lines of intersection.

11008

Reg. No.:.....

Name:.....

APJ ABDUL KALAM TECHNOLOGICAL UNIVERSITY
FIRST/SECOND SEMESTER B.TECH DEGREE SPECIAL EXAMINATION, SEPT 2016

Course Code: BE110

Course Name: ENGINEERING GRAPHICS

Max. Marks: 50

Duration: 2 Hours

PART A

Answer ANY ONE question (11 Marks)

1. The front and top views of an 80 mm long line PQ measures 70 mm and 60 mm, respectively. The end P is on the HP and the end Q is in the VP. Draw the projections of line PQ and determine its inclinations with the HP and the VP. Also, locate the traces.
2. A room is 4.8 m x 4.2 m x 3.6 m high. Determine graphically, the distance between a top corner and the bottom corner diagonally opposite to it.

PART B

Answer ANY THREE Questions (13 marks each)

3. A square pyramid of base side 30 mm and axis length 60 mm is resting on HP on one of its triangular faces with its axis parallel to VP. Draw its projections.
4. A frustum of a cone of base diameter 50 mm, top diameter 30 mm and height 45 mm is resting upon its base on HP. Draw the isometric projection of the frustum.
5. A pentagonal prism, having a base with a 30 mm side and a 70 mm long axis, is resting on its base on H.P. such that one of the rectangular faces is parallel to the V.P. It is cut by an auxiliary inclined plane making an angle 45° with the H.P. and passes through the midpoint of the axis. Draw the sectional top view, true shape of the section and the development of the lateral surface of the truncated prism.
6. A horizontal cylinder of 50 mm diameter and 100mm long penetrates a vertical cylinder of 80mm diameter and 120mm long resting on HP. The axis of the horizontal cylinder is parallel to VP and 60 mm above the HP. Draw the projection showing the curve of the intersection.

C**B1C001****Total Page:1**

Reg. No. _____

Name: _____

APJ ABDUL KALAM TECHNOLOGICAL UNIVERSITY
FIRST SEMESTER B.TECH DEGREE EXAMINATION, JANUARY 2017
(Regular & Supplementary)

Course Code: **BE 110**Course Name: **ENGINEERING GRAPHICS**

Max. Marks : 50

Duration : 3 Hours

PART A*Answer ANY TWO question (2x10=20 Marks)*

1. A line AB inclined at 45° to VP has its ends 20 mm and 50 mm above HP. The length of its front view is 70 mm and its VT is 10 mm above HP. Find its true length, true inclination with HP and locate its traces.
2. An electric lamp is hung vertically from the centre of the flat roof of a room (5m x 5m and height 6m), at a height of 4m above the floor. Find graphically the distance between the lamp and any one of the floor corner.
3. A square pyramid 40mm base edge and 60 mm height is on HP with one of its base edges so that the axis is making 45° with HP and the base edge making 30° with VP. Draw the projections

PART B*Answer ANY THREE question (3x10=30 Marks)*

4. A cone of base diameter 50 mm and axis 65 mm is resting upon its base on HP. It is cut by a vertical plane which makes an angle of 45° with VP and is 10 mm away from the axis. Draw the sectional front view showing the section and true shape of the section.
5. A sphere of radius 25 mm rests centrally on the top of the frustum of a square pyramid of 40 mm side of base and 20 mm side at the top and the axis is 50 mm long. Draw the isometric projection of the solids in the given position.
6. A right circular cylinder of base diameter 50 mm and height 70 mm resting upon HP on its base. An insect starts from a point on the base edge at the bottom, moves around the curved surface of the cylinder and reaches the top after completing two revolutions along the shortest path. Draw the development and sketch the path of the insect in the front view.
7. A rectangular pyramid base 35 mm x 45 mm and axis 50 mm long is resting on its base on the ground plane such that one of its longer edges of base is touching on the picture plane. Draw the perspective view of the pyramid, if the station point is 60 mm in front of picture plane 35 mm above ground plane and in the central plane which is 50 mm to the left of the axis of the pyramid.
8. A vertical cylinder of 60 mm diameter has a circular hole of 30 mm side cut through the centre of the cylinder. The axis of the hole is horizontal and 8 mm from the axis of the cylinder. Draw the projection showing the curve of intersection of the hole. The axis of the hole is parallel to VP. Assume suitable height for the prism.

Reg. No. _____

Name: _____

APJ ABDUL KALAM TECHNOLOGICAL UNIVERSITY
SECOND SEMESTER B.TECH DEGREE EXAMINATION, MAY 2017

Course Code: **BE110**Course Name: **ENGINEERING GRAPHICS**Max.Marks:50Duration:3Hours**PART A***Answer ANY Two questions. 10 marks each.*

1. A line AB 100 mm long and end A 30 mm from HP, 50mm from VP, 30 degree inclined to HP and 45 degree inclined to VP. Draw the projections of line and locate its traces. Assume the line in first quadrant.
2. A square pyramid has base 30 mm and side axis 50 mm long. It is freely suspended from one of the corners of its base. The axis is parallel to the VP. Draw the projections of the pyramid.
3. A cube resting one of its base corner in such a way that one of its solid diagonal perpendicular to VP. The length of solid diagonal of cube is 80 mm. Draw the projections of the cube.

PART B*Answer ANY Three Questions. 10 marks each.*

4. Draw the isometric view of a sphere of size 40 mm diameter placed centrally over another sphere of size 60 mm diameter.
5. Draw the orthographic views from T and F directions for the following figure.

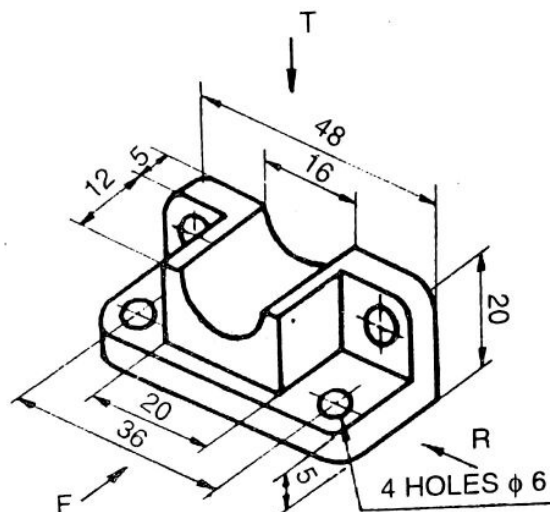

6. A cube of 65 mm long edges has its vertical faces equally inclined to the VP. It is cut by a section plane perpendicular to the VP so that the true shape of the section is a regular hexagon. Determine the inclination of the cutting plane with HP and draw the sectional top view and true shape.
7. A pentagonal prism, having a base with a 30 mm side and a 70 mm long axis, is resting on its base on H.P. such that one of the rectangular faces is parallel to the V.P. It is cut by an auxiliary inclined plane making an angle 45° with the H.P. and passes through the midpoint of the axis. Draw the sectional top view, and the development of the lateral surface of the truncated prism.
8. A square pyramid 40mm base edge and height 80 mm is resting on its base on the ground plane with one edge 45° inclined to PP which is 30 mm in front of the object. The station point is 50 mm. in front of the PP, 100 mm above the ground plane and lies in a vertical plane which is 40mm towards right of center of the pyramid. Draw the perspective view of the block.

Reg No.: _____

Name: _____

APJ ABDUL KALAM TECHNOLOGICAL UNIVERSITY
FIRST SEMESTER B.TECH DEGREE EXAMINATION DECEMBER 2017

Course Code: BE110

Course Name: ENGINEERING GRAPHICS

Max. Marks: 50

Duration: 3 Hours

PART A

Answer any two full questions, each carries 10 marks.

- 1 A straight line PQ is 100 mm long. The end P is in HP and 20 mm in front of VP. The line PQ is inclined at 30° to the HP and 20° to VP. Draw the projections of the line if the end Q is in second quadrant. (10)
- 2 The line AB measuring 60 mm has its VT 15 above HP. The end B is 30 mm above HP and 35 mm in front of VP. The projectors through B and VT are 80 mm apart. Draw the projection and find the inclination of the line with HP and VP. (10)
- 3 Draw projections of a cone of base diameter 30mm and height 40 mm resting on HP on its generator with top view of axis inclined 30° to VP (10)

PART B

Answer any three full questions, each carries 10 marks.

- 4 A vertical cylinder of base diameter 40 mm and height 35 mm is resting on ground. A sphere of diameter 20 mm resting centrally over the top face of cylinder. Draw the isometric view of combination. (10)
- 5 A square prism having base of side 30 mm, is cut by a sectional plane such that the true shape is a hexagon having two opposite sides 25 mm long and the remaining four sides 40 mm long. Draw top view, front view and true shape. Determine the height of the prism. (10)
- 6 A hexagonal prism of 20 mm base and 60 mm height resting on its base on HP such that two base edges are perpendicular to VP. It is cut by a surface which is inclined at 30° to HP and perpendicular to VP. This plane passing through the midpoint of the axis of the prism. Draw the development of bottom portion (10)
- 7 A horizontal cylinder of 40 mm diameter penetrates a vertical cylinder of 60 mm diameter resting on HP. The two axes are coplanar. Draw the projections showing the curve of the intersection (10)
- 8 Draw the perspective view of a square prism of base side 30mm and height 60mm resting on its base with one of the base edges 10mm behind and parallel to PP. The Central Plane is passing through the axis of prism and SP is located 50mm in front of PP and 40 mm above GP. (10)

Reg No.: _____

Name: _____

APJ ABDUL KALAM TECHNOLOGICAL UNIVERSITY
FIRST/SECOND SEMESTER B.TECH DEGREE EXAMINATION, APRIL 2018

Course Code: BE110

Course Name: ENGINEERING GRAPHICS

Max. Marks: 50

Duration: 3 Hours

PART A

Answer any 2 full questions, each carries 10 marks.

- 1 The plan pq of a straight line PQ is 70mm long and makes an angle of 45° with XY. (10)
The end P is in VP and 15mm above HP. The end Q is 30mm above HP and the whole line lies in the first quadrant. Draw the projections and obtain: -
i) True length ii) Elevation length iii) Inclination to reference planes iv) Traces
- 2 The top view of a 75mm line measures 65mm while the length of its front view is 50mm. Its one end is on the HP and 15mm in front of VP. Draw the projections and find its inclinations. (10)
- 3 A cone having base 50mm diameter and 65mm long axis has one of its generators in the HP and is inclined at 50° to the VP. Draw its projections when its apex being nearer to the VP. (10)

PART B

Answer any 3 full questions, each carries 10 marks.

- 4 A sphere with 60mm diameter is surmounted centrally on the top of a square block with 70mm side and 20mm height. Draw the isometric view of the combination of solids. (10)
- 5 A cone of base diameter 40mm and axis length 50mm is kept on HP on its base. It is cut by a vertical section plane which is parallel to VP and 10mm in front of the axis of the cone. Draw the sectional front view, top view and true shape of the section. (10)
- 6 A cylinder having base diameter 50mm and axis length 70mm has its base in HP. A square hole of side 25mm is drilled centrally having its sides equally inclined with HP, its axis being perpendicular to VP and bisecting the axis of the cylinder. Draw the development of the cylinder with the hole. (10)
- 7 A cube of 25mm side is placed vertically with one of its edges touching the picture plane and the vertical edge formed by the two adjacent rectangular faces, which are inclined at 45° to the picture plane. Draw the perspective view of the cube, if the station point is 70mm in front of the picture plane, lies in a central, containing the center of the cube and 50mm above the ground. (10)
- 8 A vertical hexagonal prism, side of base 40mm and 80mm long is completely penetrated by a horizontal square prism of 35mm side and 100 mm length. The axis of the horizontal prism is parallel to VP. If one of the rectangular face of the hexagonal prism is parallel to VP and all the faces of the square prism are equally inclined to HP, draw the projections of the prisms showing the lines of intersection. (10)

Reg No.: _____

Name: _____

APJ ABDUL KALAM TECHNOLOGICAL UNIVERSITY
FIRST/SECOND SEMESTER B.TECH DEGREE EXAMINATION, JULY 2018

Course Code: BE110

Course Name: ENGINEERING GRAPHICS

Max. Marks: 50

Duration: 3 Hours

PART A

Answer any two questions, each carries 10 marks

Marks

- | | | |
|---|---|------|
| 1 | A line PQ 108mm long has its plan and elevation lengths 60 mm and 90 mm respectively. One end of the line P is in HP while the other end is in VP. Draw its projections and locate the traces. | (10) |
| 2 | A room measures 8m long, 5m wide and 4m high. An electric point hangs in the centre of the ceiling and 1m below it. A thin straight wire connects the electric point to a switch kept in one of the corners of the room and 2m above the floor. Draw the projections of the wire. Find the true length and the slope of angle of the wire with the floor. | (10) |
| 3 | A hexagonal pyramid of base side 30 mm, axis length 60 mm is resting on HP on one of its triangular faces with its axis parallel to VP. Draw its projections. | (10) |

PART B

Answer any three questions, each carries 10 marks

- | | | |
|---|--|------|
| 4 | A right circular cone, 60 mm of base diameter and 80 mm altitude is resting with its base on the HP and is cut by a plane parallel to one of its generators and bisecting the axis. Draw the true shape of the section. Name the curve obtained. | (10) |
| 5 | A horizontal cylinder 40 mm diameter and axis length 75 mm centrally penetrates a vertical cylinder 50 mm as base diameter. Draw the plan and elevation, showing curves of intersection. Assume the axis of the horizontal cylinder is parallel to VP. | (10) |
| 6 | Draw the isometric view of a frustum of a square pyramid with its base on the ground. The base side = 70 mm. The side length at the top is 30 mm. The height = 70 mm. | (10) |
| 7 | A square prism of base 3 cm x 3 cm and height 6 cm stands on GP with the edge of base making 45° with PP. The nearest corner is 3 cm to the right of station point and 3 cm behind the PP. The station point is 5 cm above the GP and 10 cm in front of the PP. Draw the perspective view of the square prism. | (10) |
| 8 | Draw the development of the lower portion of a cylinder of diameter 50 mm and axis 70 mm when sectioned by a plane inclined at 40° to HP and perpendicular to VP and bisecting the axis. | (10) |

Reg No.: _____

Name: _____

APJ ABDUL KALAM TECHNOLOGICAL UNIVERSITY
FIRST SEMESTER B.TECH DEGREE EXAMINATION, DECEMBER 2018

Course Code: BE110

Course Name: ENGINEERING GRAPHICS

Max. Marks: 50

Duration: 3 Hours

PART A

Answer any two questions, each carries 10 marks.

Marks

- 1 A line AB has its point A in HP and 30 mm in front of VP. Point B in VP and 60mm above HP. The distance between end projectors are 70 mm. Draw the projections and find true length of line and inclinations with HP and VP. (10)
- 2 The point A of a line is 40 mm above HP and 20 mm in front of VP. The point B is 30 mm below HP and 50 mm behind VP. The distance between end projectors is 100 mm. Find the true length of the line and its inclination with HP and VP. (10)
- 3 A pentagonal prism of base edge 30 mm and height 70 mm is resting on HP on its base edge such that the rectangular face containing that edge is inclined 45° to HP and the base edge on which it is resting is inclined 30° to VP. (10)

PART B

Answer any three questions, each carries 10 marks.

- 4 Draw the isometric view of a right regular hexagonal prism of side of base 30mm and height 70mm resting on its base on HP, having a through circular hole of diameter 30mm drilled centrally through it along the axis. (10)
- 5 Figure shows the isometric view of a machine component with all the dimensions in mm. Draw its front view, top view and any one side view. Arrow (X) indicates the direction to obtain the view from the front. (10)

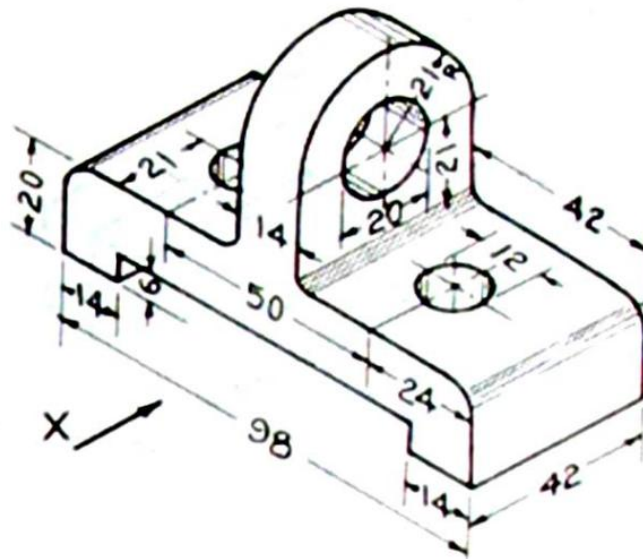

- 6 A cone of base diameter 60 mm and axis length 70 mm is resting on HP on its base. It is cut by a section plane which is perpendicular to VP and parallel to the right most generator in the front view, and section plane is 10 mm away from this generator. Draw the front view, sectional top view and true shape of the section. (10)

- 7 A pentagonal prism, having a base with a 30 mm side and a 70 mm long axis, is resting on its base on H.P. such that one of the rectangular faces is parallel to the V.P. it is cut by an auxiliary inclined plane making an angle 45° with the H.P. and passes through the midpoint of the axis. Draw the development of the lateral surface of the truncated prism. (10)
- 8 A square prism of base side 35mm and axis length 65mm is resting on one of its rectangular faces on GP. The base nearer to PP is parallel to it and 15mm behind it. The station point is 50mm to the left of the axis of the prism, 55mm above the ground plane and 30mm in front of the picture plane. Draw the perspective view of the prism. (10)

Reg No.: _____

Name: _____

APJ ABDUL KALAM TECHNOLOGICAL UNIVERSITY
FIRST/SECOND SEMESTER B.TECH DEGREE EXAMINATION, MAY 2019

Course Code: BE110

Course Name: ENGINEERING GRAPHICS

Max. Marks: 50

Duration: 3 Hours

PART A

Answer any two questions, each carries 10 marks.

- | | | Marks |
|---|---|-------|
| 1 | A line AB 70mm long is inclined at 30° to HP and 40° to VP. The end A is in HP and 40mm in front of VP. Draw its projections and locate the traces. | (10) |
| 2 | Front view of a line AB makes 50° with xy- line and measures 60 mm and its top view makes 30° with xy- line. End A is 15 mm above HP and its VT is 10 mm below HP. Draw projections of the line AB, determine inclinations with HP and VP, true length and locate its traces. | (10) |
| 3 | A triangular prism of base side 30mm and length 50mm has a base edge on HP, axis inclined at 35° to HP. The base edge on which it rests is inclined 45° to VP. Draw the projections of solid | (10) |

PART B

Answer any three questions, each carries 10 marks.

- | | | |
|---|--|------|
| 4 | Draw an isometric view of a frustum of a cone 25mm top diameter and 40mm bottom diameter and 50mm high placed centrally above a cylindrical block of 50mm diameter and 25mm thick such that the solids have a common axis. | (10) |
| 5 | Draw front view, top view and any one side view of the following figure, F is the front view direction. | |

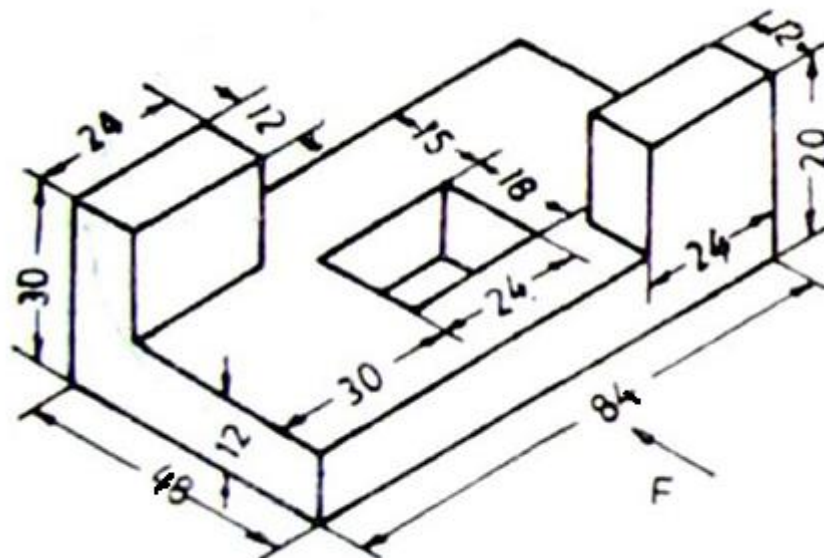

- | | | |
|---|---|------|
| 6 | A square prism of 40 mm side length and 60 mm height rests on its base upon HP, such that the vertical faces are equally inclined to VP. A horizontal hole 40 mm diameter is drilled through the geometrical centre of the prism with the axis perpendicular to VP. Develop the lateral surface of the prism. | (10) |
| 7 | A vertical cylinder of height 70mm and base circle diameter 60mm is resting on the ground on its base and a horizontal cylinder of base 40mm diameter and axis | (10) |

- length 80mm penetrates the vertical cylinder by bisecting the axes at right angles to each other. Draw the projection of the solids showing the curve of intersection.
- 8 A pentagonal pyramid axis length 50mm and base edge 25mm is resting on GP on its base. One of the base edges which is nearer to PP is parallel to it and 15mm behind it. The SP is 65mm above GP and 40mm in front of PP. Draw the perspective view of the pyramid if the axis is lying on the central plane and the pyramid is completely behind the PP. (10)

Reg No.: _____

Name: _____

APJ ABDUL KALAM TECHNOLOGICAL UNIVERSITY
FIRST SEMESTER B.TECH DEGREE EXAMINATION(S), DECEMBER 2019

Course Code: BE110

Course Name: ENGINEERING GRAPHICS

Max. Marks: 50

Duration: 3 Hours

PART A

Answer any two questions, each carries 10 marks.

- | | | Marks |
|---|---|-------|
| 1 | The front view of a line AB measures 60mm and makes an angle of 40° with xy-line. The end A is in HP and VT of the line is 15mm below HP. The line is inclined at 30° to VP. Draw the projections and find the true length and locate HT. | (10) |
| 2 | Draw the projections of a straight line AB 100 mm long inclined at 45° to HP and 30° to the VP. The end A is in HP and B is in VP. | (10) |
| 3 | A square pyramid of base edge 30mm and the height 60 mm is resting on HP on its triangular face such that the square face edge on HP is inclined 30° to VP. Draw its projections | (10) |

PART B

Answer any three questions, each carries 10 marks.

- | | | |
|---|---|------|
| 4 | A sphere with 60mm diameter is surmounted centrally on the top of a square block with 70mm side and 20mm height. Draw the isometric view of the combination of solids. | (10) |
| 5 | A cone of base diameter 50 mm and axis 60 mm long is resting on its base on the HP. It is cut by a plane bisecting the axis inclined at 45° to the H.P. Draw its sectional top view and true shape of the section. | (10) |
| 6 | A square pyramid of base side 40 mm is resting on its base on HP, with two of its base sides are parallel to VP. A section plane which is parallel to resting base and perpendicular to VP cuts the pyramid at a distance of 50 mm from its base. Edge of the square face formed after removing the top portion of the pyramid is 20 mm. Draw the development of the lateral surface of the bottom portion of sectioned solid. | (10) |
| 7 | A square prism base 45 mm side and 100 mm long is resting on its square base on HP with the two adjacent vertical faces equally inclined to VP. It is penetrated by a triangular prism 45 mm side and 90 mm long in such a way that these axes intersect each other at right angles at their mid points. If the two rectangular faces of the triangular prism are equally inclined to horizontal plane draw the projection of solids showing the lines of intersection. | (10) |
| 8 | A square pyramid 45mm base edge and axis 60mm high, rest on the base with one edge of the base parallel to and 25mm behind the picture plane. The central plane is 50mm to the left of the apex. The station point is 45mm in front of the picture plane and 30mm above the ground plane. Draw the perspective view of the pyramid. | (10) |

Reg No.: _____

Name: _____

APJ ABDUL KALAM TECHNOLOGICAL UNIVERSITY
B.Tech examinations (S) September 2020 S1/S2 (2015 Scheme)

Course Code: BE110

Course Name: ENGINEERING GRAPHICS

Max. Marks: 50

Duration: 3 Hours

PART A

Answer any two questions, each carries 10 marks.

Marks

- | | | |
|---|---|------|
| 1 | The point A of a line AB is in HP and 60mm in front of VP, the point B is in VP and 40mm above HP. The distance between projectors is 70mm. Draw the projections of the line, find the true length, inclinations and locate the traces. | (10) |
| 2 | A straight line AB measuring 120 mm long has its vertical trace 80mm above xy- line and the HT 100 mm below the xy- line. The projectors through the HT and VT are 110 mm apart. If the point A is 10 mm above HP, draw the projections of AB and find its true inclinations with respect to HP and VP. | (10) |
| 3 | Draw the projections of a cylinder rests on HP which has 60mm diameter and 70mm height, if the base face makes an angle 45° to HP and top view of axis makes 30° to VP. | (10) |

PART B

Answer any three questions, each carries 10 marks.

- | | | |
|---|--|------|
| 4 | Draw the isometric view of the frustum of a cone with 60mm base diameter and 40mm top diameter and 70mm height resting on its base on the HP. | (10) |
| 5 | A pentagonal pyramid of base side 30 mm and axis 60 mm is resting on its base on the H.P. with an edge of the base nearer the VP, parallel to it. A vertical section plane inclined at 45° to the VP, cuts the pyramid at a distance of 8 mm from the axis. Draw its sectional front view, top view and true shape of the section. | (10) |
| 6 | A square pyramid with 30 mm side of base and 50 mm long axis is resting on its base such that all the sides of the base are equally inclined to the V.P. It is cut by a section plane perpendicular to V.P. and inclined at 60° to H.P. The section plane is passing through the mid-point of the axis. Draw the development of bottom portion of the cut pyramid. | (10) |
| 7 | A square prism of base edge 35mm and axis height 65mm is completely penetrated by a horizontal square prism of base edge 25mm and axis length 75mm. The axes of the two prisms are bisecting each other at right angles to each other and the faces of the prisms are equally inclined to the vertical plane. Draw the projection of the prisms showing the lines of intersection. | (10) |
| 8 | A hexagonal pyramid of height 60mm and base edge 35mm is resting on its base with one base edge parallel and 15mm behind PP. The station point is 20mm in front of PP, 38mm to the right of the axis and 70mm above GP. Draw the perspective view. | (10) |
