

Reg. No. \_\_\_\_\_ Name: \_\_\_\_\_

**APJ ABDUL KALAM TECHNOLOGICAL UNIVERSITY**  
FOURTH SEMESTER B.TECH DEGREE EXAMINATION, MAY 2017

Course Code: **ME202**

Course Name: **ADVANCED MECHANICS OF SOLIDS (ME)**

Max. Marks: 100

Duration: 3 Hours

**PART A**

*Answer any three questions.*

1. The stress tensor at a point is given by the following matrix

$$\begin{bmatrix} 50 & -20 & 40 \\ -20 & 20 & 10 \\ 40 & 10 & 30 \end{bmatrix} \text{ kPa.}$$

Determine the stress on a plane whose unit normal has direction cosines  $\frac{1}{\sqrt{2}}$ ,  $\frac{1}{2}$  and

$$\frac{1}{2}. \quad (10)$$

2. Displacement field for a 2D plane strain case is given as,

$$u = [(x^2 + xy)\hat{i} + (y^2 + xy)\hat{j}] \times 10^{-2}$$

- a) Find components of strain at point (2,4) (3)
- b) Write strain compatibility equations for a general 3D problem (2)
- c) Simplify the compatibility equations, for 2D plane strain problem, with proper justification, and check compatibility of the given displacement field. (5)
3. a) State and explain Saint Venant's principle for end effects with a suitable example. (5)
- b) State and prove uniqueness theorem in theory of elasticity. (5)

4. Stress components at a point P in a plane stress problem are,

$$\sigma_{xx} = 150 \text{ MPa}, \quad \sigma_{yy} = -100 \text{ MPa} \quad \& \tau_{xy} = 50 \text{ MPa} .$$

Find values of all principal strains and it directions at point P. Take the value for

$$E = 210 \text{ GPa} \quad \& \quad \nu = 0.25 \quad (10)$$

**PART B**

*Answer any three questions.*

5. Derive equations of equilibrium for an axisymmetric problem. (10)
6. Consider a thin large rectangular plate, with a small hole at the centre, subjected to uniform tensile stress from its two ends. Find the variations of stress components around the hole by Airy's stress function method. (10)

7. Determine the maximum stress in the section A-A as shown in the figure 1. Also mark the region in section A-A where the absolute value of stress is more than  $8000 \text{ N/cm}^2$ . (10)

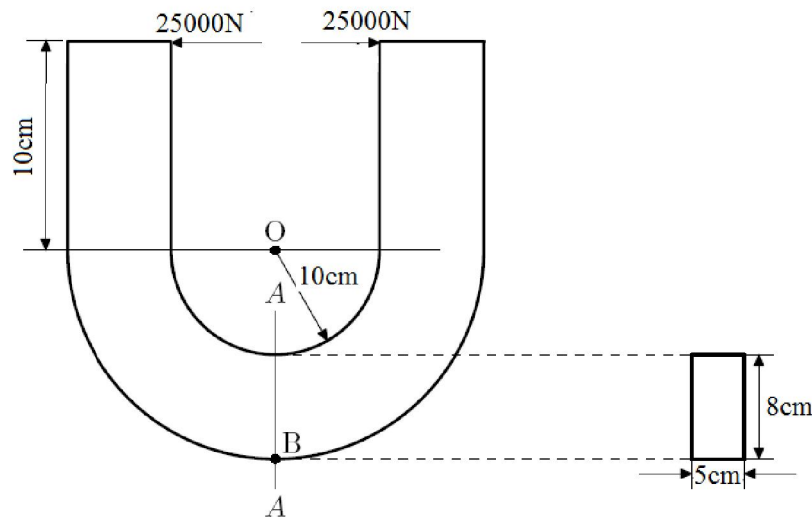

Figure 1

8. State and prove reciprocal relation in energy methods, and explain its application with an example. (10)

### PART C

*Answer any four questions.*

9. Check whether the function,  $\psi = \text{constant}$ , is a possible warping function for solving torsion problem of prismatic bar using Saint Venant's method. If so, find
- shape of the cross section corresponding to the above function, (3)
  - torsional rigidity of the prismatic bar, (3)
  - angle of twist per unit length on applying a torque T and (1)
  - stress components and resultant stress. (3)
10. Explain the principle of virtual work in energy methods, and its application in finding load and displacement at a point. (10)
11. (a) Explain the application of membrane analogy in solving torsion problem, of prismatic bar of any cross section, for finding twisting moment and shear stress acting on the cross section. (6)

- (b) State and prove Maxwell's reciprocal theorem. (4)
12. Find the angle of twist per unit length when the two cell tubular section, as shown in figure 2 is subjected to a torque of  $30,000 \text{ Nm}$ . Take value of  $G = 160 \times 10^9 \text{ N/m}^2$  (10)

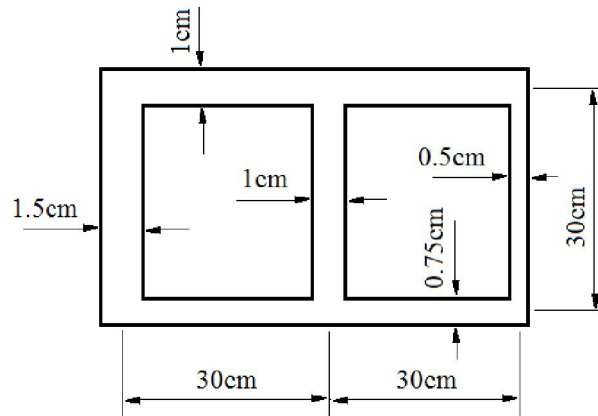

Figure 2

13. Use Prandtl's method to derive equations for the components of stress, the maximum value of resultant stress and torsional rigidity of a prismatic bar with elliptic cross section. (10)
14. Derive an equation for angle of twist per unit length for a thin walled tube subjected to a torque,  $T$ . (10)

\*\*\*

**Total Pages:3**

Reg No.: \_\_\_\_\_

Name: \_\_\_\_\_

**APJ ABDUL KALAM TECHNOLOGICAL UNIVERSITY**  
**FOURTH SEMESTER B.TECH DEGREE EXAMINATION, JULY 2017**

**Course Code: ME202**

**Course Name: ADVANCED MECHANICS OF SOLIDS (ME)**

Max. Marks: 100

Duration: 3 Hours

*(Data handbooks not permitted)*

**PART A**

*Answer any three questions. Each question carries 10 marks.*

- 1 a) What is meant by the state of stress at a point? (3)
- b) The state of stress at a point is characterised by  $\sigma_x=18$   $\sigma_y= - 50$ ,  $\sigma_z= 32$   $\tau_{xy} = 0$ ,  $\tau_{xz}= 24$ ,  $\tau_{yz}= 0$  (All stress values are in kPa); Calculate the principal stresses and the direction of largest tensile principal stress? (7)
- 2 a) Explain the plane stress and strain with ONE example each? (4)
- b) A displacement field  $u=2xyi+3zk$  where  $i$  and  $k$  are unit vectors along  $x$  and  $z$  directions is acting at  $(1, 1, 0)$ . Find the rectangular components of strain and obtain the state of strain matrix? (6)
- 3 a) Describe the Airy's stress function with the help of second degree polynomial? (4)
- b) Obtain the bending stress on the cross section of a cantilever beam carrying point load at the free end using polynomial stress function method? (6)
- 4 a) Write the generalized Hook's law for an isotropic material. (5)
- b) State and prove uniqueness theorem. (5)

**PART B**

*Answer any three questions. Each question carries 10 marks*

- 5 a) Obtain the stress distribution in a rotating solid disc of radius 'b' with no external forces at the outer surface. (7)
- b) Sketch the circumferential stress distribution for a thick cylinder subjected to internal pressure only. (3)
- 6 a) Draw the stress distribution around a small hole (diameter 'b'), on a thin plate having large width ('a') where  $b \ll a$ , subjected to uniform tensile forces at the two edges. (4)

- b) What are the assumptions involved in axisymmetric problems. Write the governing equilibrium equations for the axisymmetric problem with sketch indicating stress components. (6)
- 7 a) Find the value of load P in Fig.1, so that the maximum bending stress allowed is 15MPa for the case of beam shown below, subjected to unsymmetrical bending. (8)

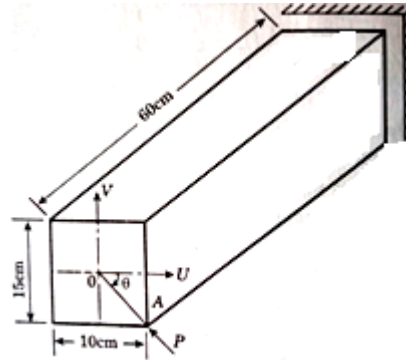

Fig.1

- b) What is meant by shear centre? (2)
- 8 a) Obtain the expression for strain energy in a bar subjected to:- (6)
- i) axial force    ii) bending moment    iii) twisting moment
- b) State and prove reciprocal relation in strain energy. (4)

### PART C

*Answer any four questions. Each question carries 10 marks.*

- 9 a) Explain the principle of virtual work? (3)
- b) State and prove Castiglianos's first theorem. (7)
- 10 a) Write the general expression for twisting moment for shafts of non-circular cross section incorporating warping function  $\Psi(x,y)$ . (3)
- b) What is meant by warping of non-circular shafts? Prove that St.Venants warping function is harmonic? (7)
- 11 a) Explain the minimum potential energy theorem? (2)
- b) Find the support reaction R in Fig.2 at the end of the cantilever beam using strain energy method. (Load acting is P at a distance of 'b' from the roller support). (8)

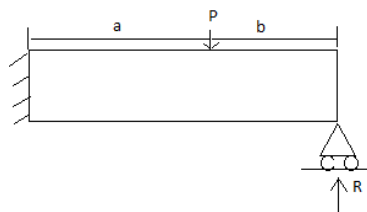

Fig.2

- 12 a) Discuss the Maxwell reciprocal theorem. (2)
- b) A shaft of square section as shown in Fig. 3 below is subjected to a twisting moment such that the maximum shear stress is limited to  $250\text{GN/mm}^2$ . Obtain the torque and angular twist, if shaft is 1.6m long (Take  $G = 70000\text{N/mm}^2$ ). (8)

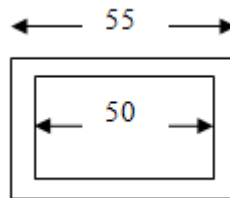

Fig.3

- 13 a) Why closed sections are having better torsional rigidity than open sections, briefly explain? (4)
- b) Find an expression for the maximum shear stress induced in an elliptical bar under torsion? (6)
- 14 a) A thin walled box section  $2a \times a \times t$  is to be compared with a solid circular section having diameter 'a' shown below in Fig.4. Find the thickness 't' so that both sections have: - (8)
- i) Same shear stress for same torque
- ii) Same stiffness.

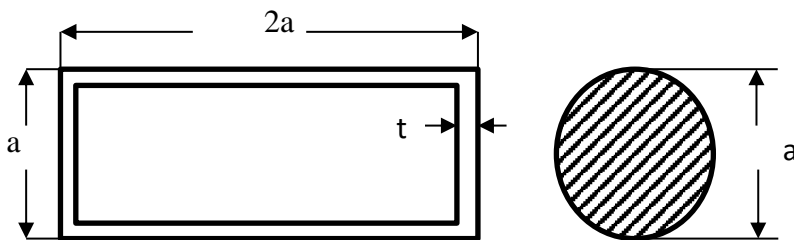

Fig. 4

- b) Define the term shear flow in a thin walled tube? (2)

\*\*\*\*

Reg No.: \_\_\_\_\_

Name: \_\_\_\_\_

**APJ ABDUL KALAM TECHNOLOGICAL UNIVERSITY**  
FOURTH SEMESTER B.TECH DEGREE EXAMINATION, APRIL 2018

**Course Code: ME202**

**Course Name: ADVANCED MECHANICS OF SOLIDS (ME)**

Max. Marks: 100

Duration: 3 Hours

*(Data handbooks not permitted)*

**PART A**

*Answer any three questions, each carries 10 marks.*

Marks

- 1 a) Define the term “State of stress” at a point. (3)  
 b) Derive the Cauchy’s equation for components of traction along the x,y and z direction. Also derive the characteristic equation for the principle stresses and principle plane from Cauchy’s equation. (7)
- 2 The state of stress at a point is given by the Cartesian stress tensor
- $$\begin{bmatrix} 2 & -1 & 1 \\ -1 & 3 & -1 \\ 1 & -1 & 2 \end{bmatrix} \text{ kPa}$$
- Find the following:
- a) The three stress invariants (3)  
 b) Characteristic equation (2)  
 c) Principal stresses (2)  
 d) Any one unit normals of the principal planes. (3)
- 3 a) State and explain Generalized Hook’s law (5)  
 b) Derive the relationship between stress and strain for an isotropic material in terms of Lamé’s coefficient. (5)
- 4 Derive the expression for stress function and components of stress for the bending of a cantilever with an end load. (10)

**PART B**

*Answer any three questions, each carries 10 marks*

- 5 a) Derive the equation for radial & hoop stress developed in a thick cylinder subjected to both internal and external pressure for a plain stress case. (6)  
 b) Plot the variation of radial and hoop stress developed inside the cylinder subjected to only internal pressure (4)
- 6 A disc with a hole has an inner radius of 10 cm and outer radius of 35 cm. If the disc is running at 3500 rpm, determine the following:
- a) The distributions of radial stress and tangential stress. (4)  
 b) Plot the variation of radial and tangential stress across the radius of the disc. (3)  
 c) Find the maximum values of radial and tangential stress. (3)
- Take Poisson’s ratio is equal to 0.3 and density of steel equal to 8050 kg/m<sup>3</sup>.
- 7 A crane hook of rectangular cross section 25 mm wide and 55 mm deep has an inner radius of curvature 80 mm. The load line is at 70 mm from the inside of the section. Determine the maximum fiber stress induced, if it carries a load of 30kN. (10)

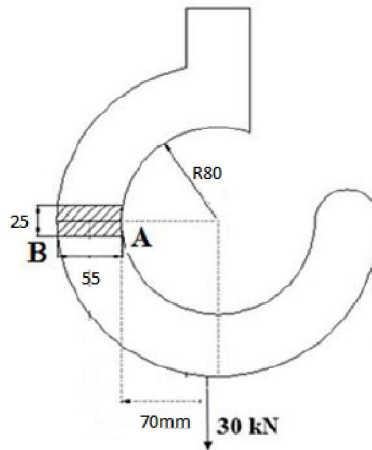

- 8 Derive the equation for strain energy for the below loading conditions:
- Strain Energy under Direct Stress. (2)
  - Strain Energy in Bending of cantilever beam with a point load and simply supported beam with concentrated load. (4)
  - Strain Energy in Torsion. (2)
  - Strain energy for shear stress. (2)

### PART C

*Answer any four questions, each carries 10 marks.*

- State and prove Castigliano's first theorem. (6)
  - State and explain Minimum Potential Energy theorem. (4)
- State and prove Maxwell's reciprocal theorem. (4)
  - Find the transverse deflection at the point 1 due to the application of a load  $P$  at 2 of the cantilever shown in figure. (6)

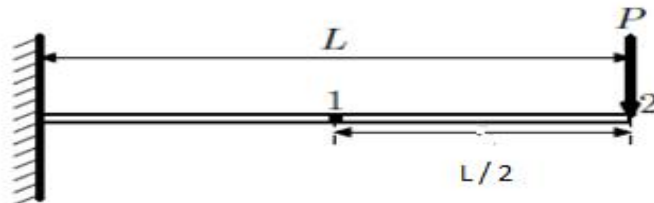

- Derive the equation for torsion of an elliptical cross section using Saint Venant's method. Also find the following: (4)
  - Angle of twist per unit length on applying a torque  $T$  (2)
  - Stress components and resultant stress. (4)
- Derive the Torsion equation for a thin walled hollow circular rod subjected to a torque  $T$ . Also state the assumptions used in the derivation. (10)

- 13 Figure shows the cross sections of two tubular rods. The thickness and (10)  
circumference of the two sections are equal. Find the ratio of shear stress induced if:  
i) Equal twisting moment, are applied ii) Equal angle of twist, are applied.

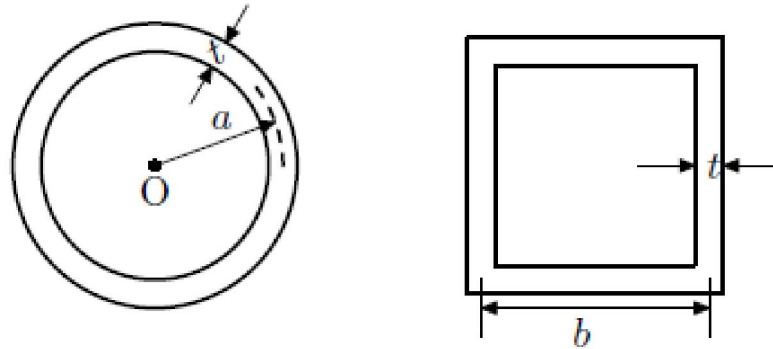

- 14 Derive the equation for torsion of a bar of circular cross section using Prandtl's (10)  
Method. Also find the components of stress and the resultant stress.

\*\*\*\*

Reg No.: \_\_\_\_\_

Name: \_\_\_\_\_

**APJ ABDUL KALAM TECHNOLOGICAL UNIVERSITY**  
FOURTH SEMESTER B.TECH DEGREE EXAMINATION, DECEMBER 2018

**Course Code: ME202**

**Course Name: ADVANCED MECHANICS OF SOLIDS (ME)**

Max. Marks: 100

Duration: 3 Hours

**PART A**

*Answer any three questions. Each question carries 10 marks.*

- 1 The state of stress at a point is characterised by the components, (10)  
 $\sigma_x = 12.31, \sigma_y = 8.96, \sigma_z = 4.34, \tau_{xy} = 4.20, \tau_{yz} = 5.27, \tau_{zx} = 0.84$  MPa.  
 Determine the values of principal stresses and maximum shear stress.
- 2 a) State St. Venant's principle for end effects. (3)  
 b) Write down the generalized Hooke's law for a linear elastic isotropic material (3)  
 c) What is meant by octahedral plane? (2)  
 d) What is plane stress? (2)
- 3 a) If the displacement field is given by  $U = (x^2 + y)\mathbf{i} + (3 + z)\mathbf{j} + (x^2 + 2 - y)\mathbf{k}$  (5)  
 Write down the strain tensor at the point (3,2,-1)  
 b) Corresponding to the above, determine the strain in the direction (5)  
 $n_x = n_y = n_z = \frac{1}{\sqrt{3}}$
- 4 a) Investigate whether the following polynomial is permissible as an Airy's stress (6)  
 function  
 $\phi = A \left( xy^2 - \frac{3}{4} xyB^3 \right)$ . If permissible, derive the expressions for stress.  
 b) Write a note on stress transformation. (4)

**PART B**

*Answer any three questions. Each question carries 10 marks*

- 5 a) What is meant by shear centre? (3)  
 b) Explain the term "complementary strain energy" (3)  
 b) Give the expressions for strain energy due to torsion (4)
- 6 a) Write down the differential equation of equilibrium in polar co-ordinate (5)  
 system in 2-dimensions.  
 b) What are the initial assumptions taken while solving problems of rotating (5)  
 circular discs
- 7 A cantilever of rectangular cross section of breadth 4cm and depth 6cm is (10)  
 subjected to an inclined load  $W$  at free end as shown in figure. The length of  
 cantilever is 2.5m and the angle of inclination of the load with vertical is  $25^\circ$ .  
 What is the maximum value of  $W$  if the maximum stress due to bending is not  
 to exceed  $200\text{N/mm}^2$ .

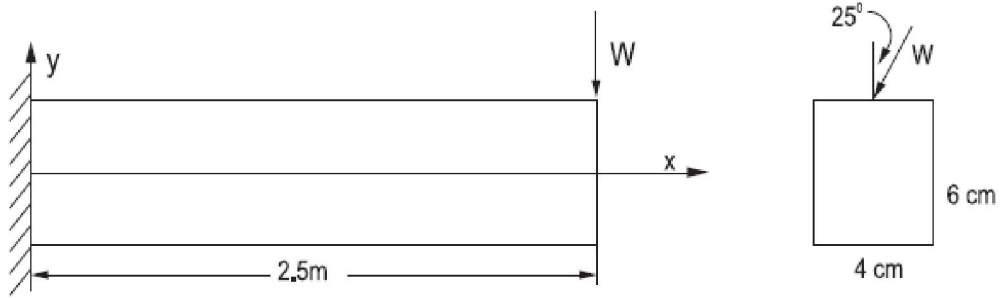

- 8 a) A thick walled tube with an internal radius of 12cm is subjected to an internal pressure of 200MPa. ( $E=2.1 \times 10^5 \text{MPa}$ ) and  $\nu = 0.3$ ). Determine the optimum value of the external radius if the maximum shear stress developed is limited to 350MPa. (6)
- b) Determine the change in internal radius due to the applied pressure. (4)

### PART C

*Answer any four questions. Each question carries 10 marks.*

- 9 a) Obtain the general expression for strain energy in terms of components of stress. (5)
- b) Explain the Maxwell reciprocal theorem. (5)
- 10 The cantilever beam supports a uniformly distributed load  $w$  and a concentrated load  $P$  as shown in figure. Also it is given that  $L=2\text{m}$ ,  $w=4\text{kN/m}$ ,  $P=6\text{kN}$  and  $EI=5\text{MN.m}^2$ . Determine the deflection at the free end using Castigliano's theorem. (10)

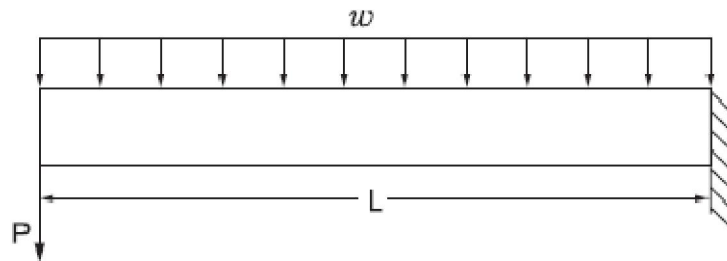

- 11 A rod with rectangular cross section is used to transmit torque to a machine frame (see figure). It has a width of 40mm. The first 3.0m length of rod has a depth of 60mm and the remaining 1.5 m length has a depth of 30mm. The rod is made of steel having  $G=77.5 \text{GPa}$ . Given  $T_1=750\text{Nm}$  and  $T_2=400\text{Nm}$ , determine the maximum shear stress in the rod. Also determine the angle of twist of the free end. (10)

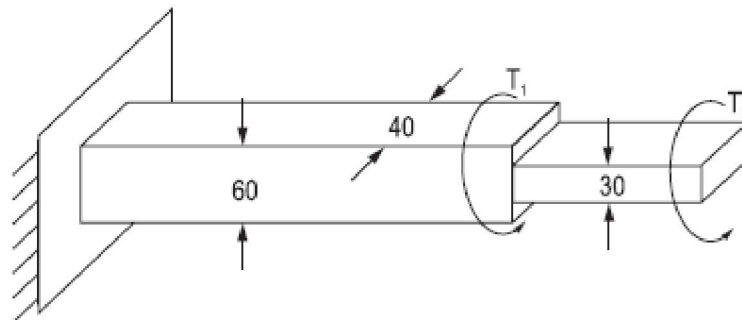

- 12 a) A shaft of square section of outer side 55mm and inner side 50mm is subjected (10)

to a twisting moment such that the maximum shear stress developed is  $250\text{N/mm}^2$ . What is the torque acting on the shaft and what is the angular twist if the shaft is  $1.6\text{ m}$  long and  $G=70000\text{N/mm}^2$

- 13 a) Explain membrane analogy (4)  
 b) What is meant by warping function? (3)  
 c) Define the term *shear flow*. (3)
- 14 A hollow thin wall torsion member has two compartments with cross sectional dimensions as given in figure. The material is an aluminium alloy having  $G=26\text{GPa}$ . Determine the torque if the maximum shear stress is  $40\text{MPa}$ . (10)

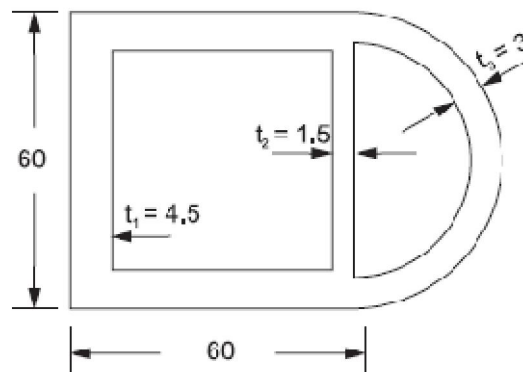

\*\*\*\*\*

Reg No.: \_\_\_\_\_

Name: \_\_\_\_\_

**APJ ABDUL KALAM TECHNOLOGICAL UNIVERSITY**  
**FOURTH SEMESTER B.TECH DEGREE EXAMINATION(R&S), MAY 2019**

**Course Code: ME202**

**Course Name: ADVANCED MECHANICS OF SOLIDS (ME)**

Max. Marks: 100

Duration: 3 Hours

**PART A**

*Answer any three full questions, each carries 10marks.*

Marks

- 1 a) Explain stress at a point in rectangular shaped member? (4)
- b) Stress at a point is given by  $\begin{bmatrix} 1 & 2 & 1 \\ 2 & -2 & -3 \\ 1 & -3 & 4 \end{bmatrix}$  k Pa. Determine principal stresses? (6)
- 2 From fundamentals derive the equilibrium equation in rectangular coordinate for two-dimensional system? (10)
- 3 A cantilever beam 4 m long having rectangular cross section of 15 cm height and 2 cm thick. This is loaded at its free end. The load at free end is 100 kN. Find maximum bending stress and maximum shear stress in the cantilever? (10)
- 4 a) Explain St. Venant's end effect with an example? (6)
- b) Explain uniqueness theorem? (4)

**PART B**

*Answer any three full questions, each carries 10marks.*

- 5 a) Sketch a 2-Dimensional element in polar coordinate (r,  $\Theta$ ) system and show all stresses on it? (4)
- b) Derive the equilibrium equation in 2-Dimensional polar coordinate system? (6)
- 6 Find the downward displacement at the point of load applied for the given figure? Cross section of members  $2 \text{ cm}^2$  and Young's modulus 200 GPa. (10)

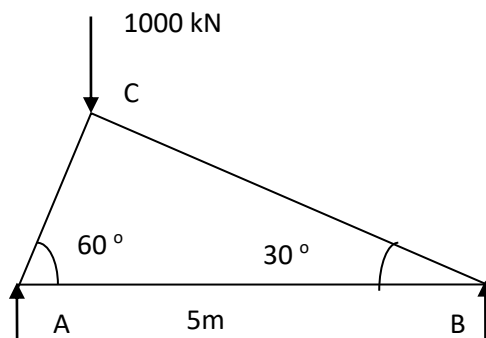

7 Derive the expression for various stresses developed in thick cylinder subjected to internal pressure only? (10)

8 Derive the expression for stress developed in curved beam subjected to bending moment 'M'? (10)

### PART C

*Answer any four full questions, each carries 10marks.*

9 State and prove Castiglione's First and Second theorems (10)

10 A cantilever beam supports a uniformly distributed load of 'w' per unit length and a concentrated load 'P' at the free end in downward direction. Take the length as 'L'. Determine the downward deflection at free end? (10)

11 A hollow aluminium section having rectangular cross section. The thickness of the section is 6 mm. Outer sides of the section having width 100 mm and height 56 mm. Find the twisting moment taken by the section and angle of twist? Modulus of rigidity is given by 28 GPa. The maximum shear stress induced is 35 N/mm<sup>2</sup>. (10)

12 a) Derive the equilibrium equation based on the membrane stress analogy? (5)

b) Find the maximum shear stress induced in an elliptical shaft having semi major axis 15 cm and semi minor axis 7.5 cm? Applied torque is 1500 Nm. (5)

13 a) State and explain virtual work principle? (5)

b) State and explain minimum potential energy theorem? (5)

14 Derive expressions for (i) Angle of twist per unit length, (ii) Torsional rigidity and (iii) Stresses, for elliptical cross section under torsion, by Prandtl's method? (10)

\*\*\*\*

Reg No.: \_\_\_\_\_

Name: \_\_\_\_\_

**APJ ABDUL KALAM TECHNOLOGICAL UNIVERSITY**  
**FOURTH SEMESTER B.TECH DEGREE EXAMINATION(S), DECEMBER 2019**

**Course Code: ME202**

**Course Name: ADVANCED MECHANICS OF SOLIDS**

Max. Marks: 100

Duration: 3 Hours

**PART A**

*Answer any three questions, each carries 10 marks*

Marks

*Databook is not permitted to use in the exam*

- 1 a) Describe about the significance of stress invariants 2  
 b) Given the stress matrix

$$[\sigma] = \begin{bmatrix} 20 & 10 & 10 \\ 10 & 20 & 10 \\ 10 & 10 & 20 \end{bmatrix} \text{ MPa}$$

- (a) Determine the principal stresses and the direction cosines associated with the maximum principal stress. 5  
 (b) Determine the maximum shear stress. 1  
 (c) Determine the octahedral stresses 2

- 2 a) Write down the strain – displacement relation in Cartesian Coordinate system 2  
 b) The displacement field for a body is given by  $\mathbf{u} = [2y^2\mathbf{i} + 4yz\mathbf{j} + (3 + 35z^2)\mathbf{k}]10^{-2}$ . Determine the strain tensor. 3

- c) State the conditions under which the following is a possible system of strains  
 $\epsilon_{xx} = a + b(x^2 + y^2) + x^4 + y^4$ ,  
 $\epsilon_{yy} = \alpha + \beta(x^2 + y^2) + x^4 + y^4$ ,  $\gamma_{xy} = A + Bxy(x^2 + y^2 - c^2)$ ,  $\gamma_{yz} = 0$ , 5  
 $\gamma_{zx} = 0$  and  $\epsilon_{zz} = 0$ .

- 3 a) For steel the Young's Modulus is  $207 \times 10^6$  kPa and Rigidity Modulus is  $80 \times 10^6$  kPa. For the strain tensor at a point, determine the stress tensor

$$[\epsilon_{ij}] = \begin{bmatrix} 0.001 & 0 & -0.002 \\ 0 & -0.003 & 0.003 \\ -0.002 & 0.003 & 0 \end{bmatrix} \quad 5$$

- b) State and explain Saint Venant's principle for end effects 3  
 c) Write the constitutive relation for linear elastic isotropic material 2  
 4 a) Obtain the stress compatibility equation for plane stress problem in the presence of body force 5  
 b) Show that  $\phi = x^4 y + 4x^2 y^3 - y^5$  is a valid stress function and compute the stress 5

tensor for this case assuming a state of plane strain with Poisson ratio  $\nu = 0.25$ .

### PART B

*Answer any three questions, each carries 10 marks*

- 5 a) Derive the compatibility equation in terms of stress function  $\phi$  for polar coordinate system 7
- b) Write the equilibrium equation in polar coordinate system 3
- 6 a) In a very thick cylinder with outer radius much larger than the inner radius  $a$ , subjected to an external pressure  $P_0$  and zero internal pressure, prove that the radial and tangential stress variations are  $\sigma_r = P_0(1 - \frac{a^2}{r^2})$  and  $\sigma_\theta = P_0(1 + \frac{a^2}{r^2})$  10
- 7 a) Obtain the strain energy in terms of material properties for a shaft subjected to a torque  $T$ . 5
- b) For a given stress tensor at a point on a steel object with  $E = 207 \times 10^6$  kPa and  $G = 80 \times 10^6$  kPa, determine the value of strain energy density. 5

$$[\sigma] = \begin{bmatrix} 9 & 0 & 3 \\ 0 & -10 & 1 \\ 3 & 1 & 112 \end{bmatrix} \times 10^3 \text{ kPa}$$

- 8 a) Explain about unsymmetrical bending of beams. 2
- b) A beam symmetrical about  $y$ - $z$  axis is subjected to a bending moment  $M$ , about an arbitrary axis in the  $y$ - $z$  plane. Obtain the equation for flexural stress. 8

### PART C

*Answer any four questions, each carries 10 marks*

- 9 a) Verify that function  $\psi(x, y) = Axy$  is a Saint Venant's warping function, where  $A$  is a constant. Find the general expression for slope of tangent at a point on the boundary curve of the bar with this warping function. Find out shape of the cross section and  $J$  integral. 8
- b) Explain about centre of twist. 2
- 10 a) Derive the governing equation and boundary condition for torsion of non circular cross section in terms of Prandtl stress function. 8
- b) What is torsional rigidity? 2
- 11 a) The aluminium ( $G = 27$  GPa) hollow thin walled torsion member has dimensions as shown below. Its length is 3m. If the member is subjected torque of 11 kN-m, determine the maximum shear stress and angle of twist. 10

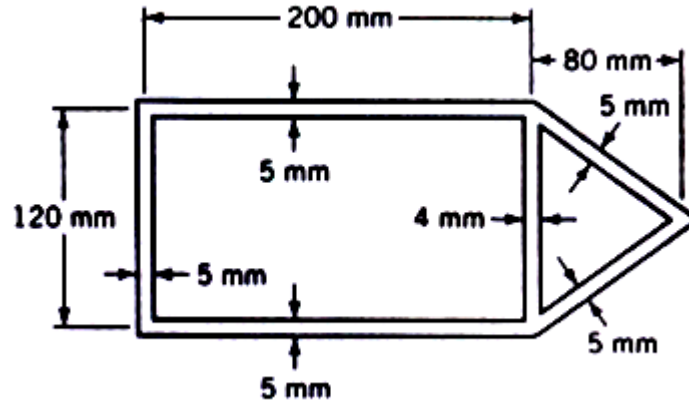

- 12 a) Based on the stress function approach, derive an expression for finding the maximum shear stress on a shaft of elliptical cross section? 10
- 13 a) A frame is subjected to a load  $P$  as shown in figure. The length of each leg is  $L$ . The frame has a constant flexural rigidity  $EI$ . If the effect of axial load is neglected, find the deflection at point  $A$  due to applied load  $P$ ? 6

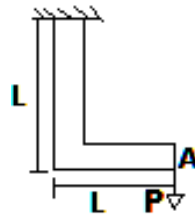

- b) State and explain Castigliano's first and second theorem 4
- 14 a) 8

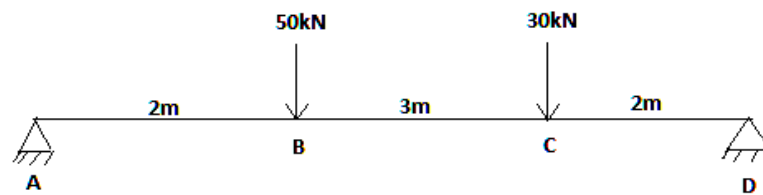

Using the principle of virtual work, find out the reactions at A and D

- b) Explain Maxwell theorem 2

\*\*\*\*

Reg No.: \_\_\_\_\_

Name: \_\_\_\_\_

**APJ ABDUL KALAM TECHNOLOGICAL UNIVERSITY**

Fourth semester B.Tech examinations (S), September 2020

**Course Code: ME202****Course Name: ADVANCED MECHANICS OF SOLIDS (ME)****Data-books are not allowed to use**

Max. Marks: 100

Duration: 3 Hours

**PART A***Answer any three full questions, each carries 10marks.*

Marks

- 1 a) If the stress tensor at a point is given by  $\sigma_{xx}=0, \sigma_{yy}=0, \sigma_{zz}=0, \tau_{xy}=10, \tau_{xz}=-10, \tau_{yz}=20$ , find stress invariants, characteristic equation, principal stresses and the principal plane associated with the maximum principal stress. (8)
- b) Find magnitude of normal and shear stress on an octahedral plane for the state of stress specified in part (a) above. (2)
- 2 If the displacement field is  $(3x^2+y) \mathbf{i} + (2y^2+z) \mathbf{j} + (4z^2+x) \mathbf{k}$ , obtain the displaced position of a point originally at (2,1,1). Also determine the strain-displacement gradient matrix and corresponding strain tensor at (2,1,1). (10)
- 3 a) Deduce the constitutive relation for a linear elastic isotropic material (5)
- b) Derive the compatibility equation in terms of Airy's stress function for a two dimensional elastic problem. Assume body forces are not acting (5)
- 4 a) Differentiate plane stress and plane strain problems with suitable examples. (4)
- b) Verify whether the function  $\phi(x,y) = \frac{C_1}{6}(x^3+y^3) + C_2xy$ , ( $C_1$  and  $C_2$  are constants) is a valid Airy's stress function. If valid, formulate stresses from it. (6)

**PART B***Answer any three full questions, each carries 10marks.*

- 5 Derive equilibrium equations in (r,θ) coordinates; Modify it to axi-symmetric case (10)
- 6 a) For a 2D axi-symmetric problem, if  $\sigma_r = \frac{E}{1-\nu^2} [A(1+\nu) - \frac{B}{r^2}(1-\nu)]$ ;  $\sigma_\theta = \frac{E}{1-\nu^2} [A(1+\nu) + \frac{B}{r^2}(1-\nu)]$ , evaluate A and B for pressures  $P_a$  and  $P_b$  at inner radius 'a' and outer radius 'b' respectively. Then modify  $\sigma_r$  and  $\sigma_\theta$  accordingly. (5)
- b) Reduce the above equations for a case with external pressure alone. Plot the variation of stresses across the thickness of the wall. (5)

- 7 Taking into account only the effect of normal stresses, determine the strain energy of the simply supported beam  $AB$  for the loading shown in figure (10)

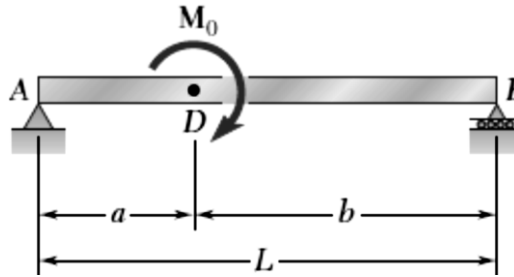

- 8 Compare bending stresses in a  $50 \times 50 \text{ mm}^2$  Square cross-section bar due to end moments of 2083 N-m for (i) straight beam and (ii) curved beam of radius 250 mm (along centroidal curve); moments causing the curve to close. (3+7)

### PART C

*Answer any four full questions, each carries 10marks.*

- 9 a) State and explain Maxwell's reciprocal theorem (3)  
 b) A structure has a vertical leg of length 'L' with the bottom part held fixed. It has a semi-circular part of radius 'r' as shown and applied by load P. Find deflection at loaded end by Castigliano's method. Consider effects due to bending moment alone. (7)

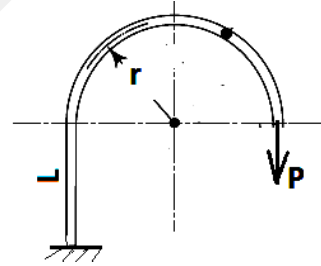

- 10 Starting from first principles, demonstrate that the St. Venant's warping function ( $\psi$ ) should obey the Laplace's equation,  $\nabla^2 \psi = 0$ . (10)
- 11 a) Explain the principle of minimum potential energy (4)  
 b) Using virtual work method, determine the displacement at the end of a cantilever beam of length 'L' subjected to a uniformly distributed load of  $w/L$ . (6)
- 12 Using Prandtl's stress function method derive the expression for (i) twist per unit length, (ii) torsional rigidity and (iii) the resultant stress for elliptical cross section under torsion. (10)
- 13 Show that the equilibrium conditions for stresses in a membrane loaded due to pressure (P) is analogous to the condition that Prandtl's torsion stress function should obey. Describe the experimental procedure of finding (i) stresses and (ii) torsional rigidity, using the membrane analogy. (10)

- 14 For the cross-section, if stress due to torsion is limited to 35,000 KPa, find (i) Limiting Torque, (ii) Corresponding Twist per unit length, (iii) Shear stress in web. Use  $G = 158 \times 10^6$  kPa,  $t = 1.25$  cm (everywhere).

