

Course Code: EET305**Course Name: SIGNALS AND SYSTEMS**

Max. Marks: 100

Duration: 3 Hours

PART A*(Answer all questions; each question carries 3 marks)*

Marks

- | | | |
|----|----------------------------------------------------------------------------------------------------------------------------------------------|---|
| 1 | Check the system given by $y(t)\frac{d^2y}{dt^2} + 3t\frac{dy}{dt} + y(t) = x(t)$ for i) causality
ii) linearity and iii) time invariance | 3 |
| 2 | Sketch the signal $u(t) - u(t - 2)$, where $u(t)$ is a unit step signal. | 3 |
| 3 | Explain the Dirichlet's conditions for existence of Fourier Transform. | 3 |
| 4 | State and prove Parseval's theorem applied to Fourier series. | 3 |
| 5 | Explain the concept of positive real functions | 3 |
| 6 | Derive the unit step response of a first order system | 3 |
| 7 | Explain a ZOH circuit and derive its transfer function | 3 |
| 8 | Find the Nyquist rate and Nyquist interval for the signal, $x(t) = \sin 200\pi t$ | 3 |
| 9 | State and prove the time reversal property of discrete time Fourier series. | 3 |
| 10 | Find the Fourier transform of the discrete signal, $x[n] = a^n u[n]$ | 3 |

PART B*(Answer one full question from each module, each question carries 14 marks)***Module -1**

- | | | |
|----|------------------------------------------------------------------------------------------------------------------------------|---|
| 11 | a) Explain the different types and properties of non-linear systems | 7 |
| | b) Find the output of a system with impulse response $h(t) = e^{-3t}u(t)$ and the input signal, $x(t) = u(t - 3) - u(t - 5)$ | 7 |
| 12 | a) For the signal shown in Fig. 1, find the signals,
i) $x(t - 2)$
ii) $x(-2t + 3)$ | 7 |

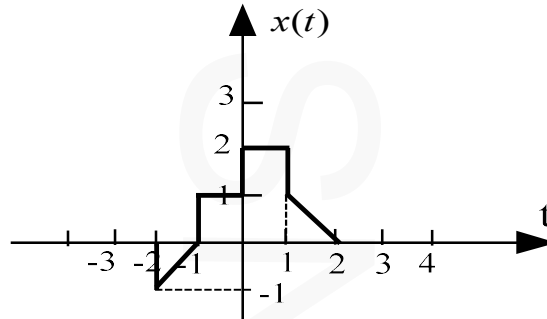

Fig. 1

- b) Differentiate energy and power signals. Determine the energy and power of the signal, $x(t) = (1 + e^{-5t})u(t)$ 7

Module -2

- 13 a) Obtain the trigonometric Fourier series expression of a half-rectified sine wave of amplitude, A. 7
- b) Find the Fourier transform of the following function: 7

$$x(t) = \cos \omega_0 t u(t)$$

- 14 a) Write the differential equations governing the behaviour of the mechanical system shown in Fig. 2. Also obtain an analogous electrical circuit based on force-current analogy. 8

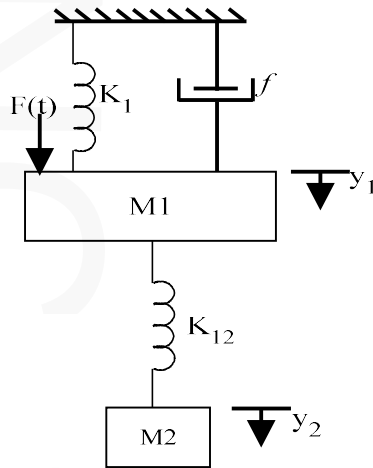

Fig. 2

- b) The differential equation of a causal, continuous-time LTI system is given by 6
- $$\ddot{y}(t) + \dot{y}(t) - 2y(t) = x(t).$$
- a) Find the transfer function $H(s)$ of the system.
- b) Find the impulse response $h(t)$ of this system.

Module -3

- 15 a) Obtain the overall transfer function, $C(s)/R(s)$ of the signal flow graph shown in Fig. 3. 14

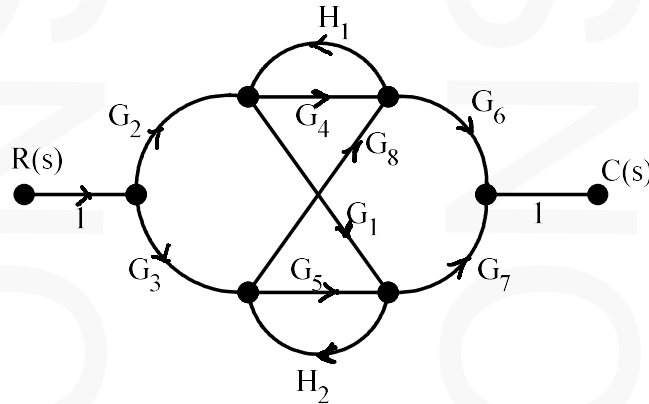

Fig. 3

- 16 a) State the necessary and sufficient conditions to be satisfied for stability of an LTI system. Prove that the necessary condition only has to be satisfied for first and second order systems. 7
- b) Analyse the stability of the given LTI system, whose characteristic equation is given by $Q(s) = s^5 + 2s^4 + 2s^3 + 4s^2 + 11s + 10$, using Routh's criterion. 7

Module -4

- 17 a) Find the inverse z- transform of $X(z) = \frac{1 - \frac{1}{3}z^{-1}}{(1 - z^{-1})(1 + 2z^{-1})}$ ROC: $|z| > 2$ 7
- b) Determine the convolution of the signals:
 $x(n) = \cos \pi n u(n)$; $h(n) = \left(\frac{1}{2}\right)^n u(n)$ 7
- 18 a) State and prove the associative property of discrete convolution. 7
- b) Find the z- transform of $x[n] = n[u[n] - u[n-8]]$ 7

Module -5

- 19 a) Find the impulse response and frequency response of the system described by the difference equation, $y[n] - \left(\frac{1}{6}\right)y[n-1] + \left(\frac{1}{6}\right)y[n-2] = x[n-1]$ 14

20 a) Check the stability of the system whose characteristic equation is given by , 6
 $z^3 + 0.2z^2 - 0.25z + 0.05 = 0$, using Jury's stability criterion.

b) The system function of a discrete time system is 8

$$H[z] = \frac{(1+z^{-1})^4}{\left(1-z^{-1} + \frac{7}{8}z^{-2}\right)\left(1+2z^{-1} + \frac{3}{4}z^{-2}\right)}$$

. Realize this system using s cascade of second order system in direct form- II.

Reg No.: _____

Name: _____

APJ ABDUL KALAM TECHNOLOGICAL UNIVERSITY

Fifth Semester B.Tech Degree Regular and Supplementary Examination December 2022 (2019 Scheme)

Course Code: EET 305**Course Name: SIGNALS AND SYSTEMS**

Max. Marks: 100

Duration: 3 Hours

PART A*(Answer all questions; each question carries 3 marks)*

Marks

- | | | |
|----|---------------------------------------------------------------------------------------------------------------------------------------------------------|---|
| 1 | Plot $x(2t)$, if $x(t) = u(-t + 2) + u(t - 3)$. | 3 |
| 2 | Find whether following signal is odd or even, $x(t) = t^4 + 4t^2 + 6$. | 3 |
| 3 | State and prove the time shifting property of Fourier Transform. | 3 |
| 4 | Derive the electrical analogous elements corresponding to elements of mechanical translational system with force voltage analogy. | 3 |
| 5 | Explain the concept of positive real functions. | 3 |
| 6 | Determine the impulse response of the system having transfer function,
$H(s) = \frac{s}{(s-2)(s+3)}$ | 3 |
| 7 | Define the process of sampling and state sampling theorem. | 3 |
| 8 | Write any three properties of z-transform. | 3 |
| 9 | Check the stability of the system represented by the following characteristic equation using Jury's test: $2z^4 + 7z^3 + 10z^2 + 4z + 1 = 0$ | 3 |
| 10 | Obtain the transfer function of given discrete time system described by the difference equation: $y(n) - \frac{5}{4}y(n-1) + \frac{1}{6}y(n-2) = 2x(n)$ | 3 |

PART B*(Answer one full question from each module, each question carries 14 marks)***Module -1**

- | | | |
|----|-------------------------------------------------------------------------------------------------------------------------------|---|
| 11 | a) Find the response of a system with an impulse response of $h(t) = u(t)$ for an input signal of $x(t) = e^{-\alpha t} u(t)$ | 8 |
| | b) Determine whether the following systems are time-invariant and linear. | 6 |
| | (i) $3 \frac{dy(t)}{dt} + 5ty(t) = x(t)$ | |
| | (ii) $\frac{dy(t)}{dt} + 10 \sin y(t) = 2x(t)$ | |
| | (iii) $y(t) \frac{dy(t)}{dt} + 10 y(t) = 2x(t)$ | |

- 12 a) For the signal, $x(t)$ shown in Fig.1, plot: (i) $x(t - 1)$ (ii) $x(-3t + 2)$

8

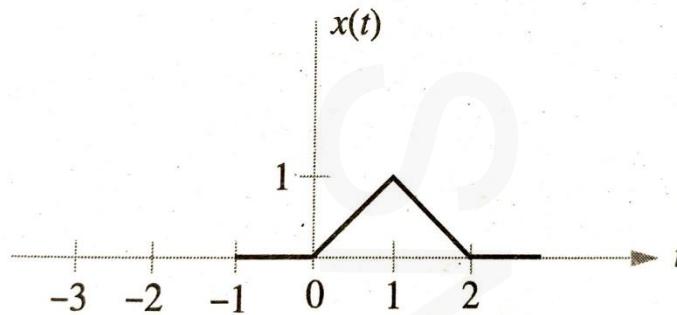

Fig.1

- b) Test whether the following signals are periodic or not. If periodic, find the fundamental period.

(i) $x(t) = 5 \sin 24\pi t + 7 \sin 36\pi t$

(ii) $x(t) = e^{j(\pi t - 2)}$

(iii) $x(t) = 5 \sin 24\pi t \cos 36\pi t$

Module -2

- 13 a) Determine the transfer function, $\frac{V_c(s)}{V_s(s)}$ of the given circuit. Hence, find the impulse response of the circuit.

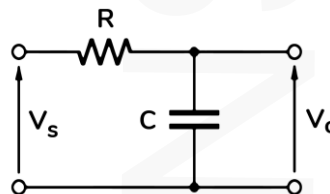

Fig.2

- b) Obtain the trigonometric Fourier Series of the given signal

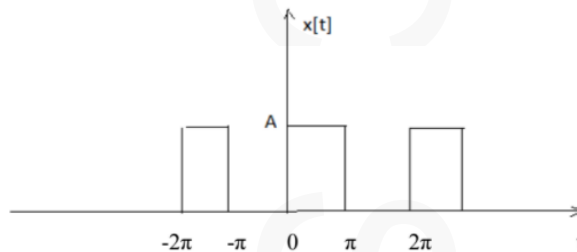

Fig.3

- 14 a) Derive the transfer function $\frac{X_2(s)}{F(s)}$ of the given mechanical system in Fig.4

10

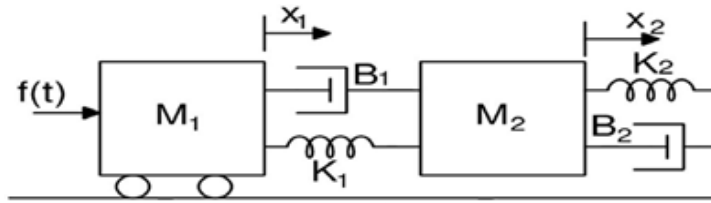

Fig.4

- b) Find the transfer function of given LTI system. 4

$$\frac{d^2y(t)}{dt^2} + 3\frac{dy(t)}{dt} + 2y(t) = 2\frac{dx(t)}{dt} - 3x(t)$$

Module -3

- 15 a) How time response can be obtained from pole zero plot. 4
 b) Describe Mason's gain formula for signal flow graph. Obtain the transfer function of the following system using Mason's gain formula. 10

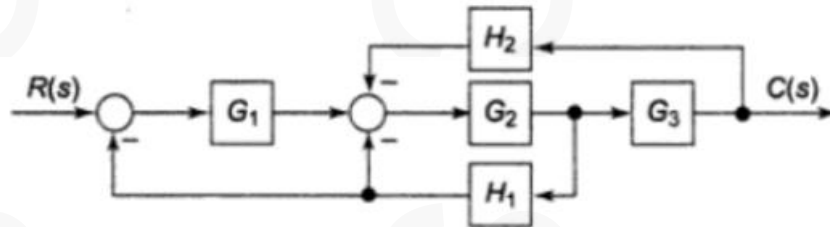

Fig.5

- 16 a) Check if the system with the given characteristic equation is stable using Routh Hurwitz stability criterion, $s^4 + 8s^3 + 18s^2 + 16s + 5 = 0$ 7
 b) Obtain the transfer function for the following system using block diagram reduction technique. 7

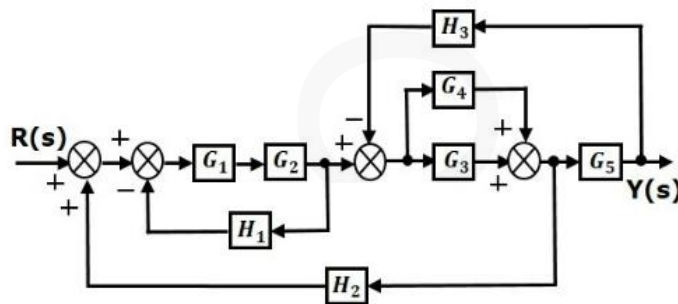

Fig.6

Module -4

- 17 a) Explain the significance of Zero order hold circuit in signal reconstruction. 4
 b) Find the inverse Z-transform of: 10

$$X(Z) = \frac{z^{-1}}{3 - 4z^{-1} + z^{-2}}; ROC|Z| > 1$$

- 18 a) List any four properties of Discrete convolution. 4
 b) Find the convolution sum of the following sequences 10

$$x(n) = 3 \delta(n + 1) - \delta(n) + 2 \delta(n - 1) + \delta(n - 2)$$

$$h(n) = 2 \delta(n) - 2 \delta(n - 1) + 2 \delta(n - 2) + \delta(n - 3)$$

Module -5

- 19 a) State and prove the time reversal property of Discrete time Fourier transform. 4
 b) A discrete system is given by the following difference equation: 10

$$y[n] - 5 y[n - 1] = x[n] + 4 x[n - 1]$$

where, $x[n]$ is the input and $y[n]$ is the output. Determine the expression for its magnitude response and phase response.

- 20 a) Check the stability of the given system using bilinear transformation: 6

$$F(z) = z^3 - 0.2z^2 - 0.25z + 0.05 = 0$$

- b) Obtain the direct form-I and direct form-II realizations of the discrete time system with system function as: 8

$$H(z) = \frac{8 - 4Z^{-1} + 11Z^{-2} - 2Z^{-3}}{1 - \frac{5}{4}Z^{-1} + \frac{3}{4}Z^{-2} - \frac{1}{8}Z^{-3}}$$
