

10026

Reg. No.: _____

Name: _____

FIRST SEMESTER B.TECH DEGREE EXAMINATION, JANUARY 2016

Course Code: EC100

Course Name: BASICS OF ELECTRONICS ENGINEERING

Max. Marks: 100

Duration: 3 Hours

PART A

Answer ALL questions. Each question carries 2 marks

1. Differentiate relays and contactors and write the applications of each.
2. What is tolerance of a resistor? Find the resistance range for the carbon resistor having the colour bands: yellow, violet, red and gold.
3. Write any four applications of electronics in the field of defence.
4. Draw the energy band diagrams of insulator, semiconductor and conductor.
5. How does an Avalanche breakdown differ from Zener break down?
6. Write the type number of the following: a) Low frequency low power transistor, b) High frequency low power transistor, c) Power Transistor, d) Rectifier Diode.
7. What is the working principle of SMPS?
8. Describe the role of different capacitors in RC coupled amplifier?
9. Define bandwidth of an amplifier and mark the important parameters in the frequency response graph.
10. Draw the internal block diagram of op-amp and write the functions of each block?
11. Realize the logic functions: Sum $S = A + B$ and Carry $C_Y = AB$ using gates and prepare the truth table.
12. What are the advantages of integrated circuits?
13. What is frequency modulation? Write the frequency bands used for AM and FM broadcast.
14. Write the RADAR range equation and list the factors affecting the range.
15. Distinguish between LEO, MEO and GEO satellites.
16. Discuss the basic principle of GPS.
17. Compare the features of GSM and CDMA.
18. Explain the total internal reflection in optical fiber with the help of a diagram.
19. What is the need for cell splitting in cellular communication system?
20. What are the characteristics of Plasma Display?

PART B

Answer any 8 complete questions each having 5 marks

21. Discuss the construction, working and application of electrolytic capacitor.
22. What is the basic working principle of transformer? List at least four different types of transformers and its applications.
23. Draw the VI characteristics of Zener diode and explain the principle of working.
24. Draw a sketch to show all the current components of an NPN transistor and derive the relation between currents.
25. Compare CB, CE and CC configurations of a transistor. Enumerate the applications of each configuration.
26. What is a full wave rectifier? Derive the expression for rectifier efficiency and ripple factor.
27. Draw the circuit diagram of a single stage RC coupled amplifier and explain the significance of each component.
28. Draw the circuit and explain the working of an inverting amplifier with op-amp and derive the expression for its closed loop gain.
29. Differentiate between analog and digital integrated circuits. Write at least four application specific integrated circuits from each group.
30. Draw the block diagram of a digital storage oscilloscope and specify the functions of each block.

Answer any 4 complete questions each having 5 marks

31. Define amplitude modulation. Draw the AM signal and its spectrum. Derive an expression for modulation index and total power in an AM signal.
32. What are the different types of RADARs and explain any one type with a block diagram.
33. What is satellite transponder? Explain its working with a block diagram.
34. Describe with the help of diagrams, how a call is established between two mobile phone subscribers.
35. Sketch the elements associated with an optical fiber communication system and describe the different types of optical fiber cables available for establishing the link.
36. Sketch the elements associated with a cable TV system and explain the functions of each.



Reg. No. :

Name :

SECOND SEMESTER B.TECH. DEGREE EXAMINATION, MAY/JUNE 2016

EC100 : BASICS OF ELECTRONICS ENGINEERING

Max. Marks : 100

Duration : 3 Hours

PART – A

Answer **all** Questions. **Each** carrying **two** marks **each**.

1. Write any four applications of electronics in the field of medical science.
2. A carbon resistor has the colour bands: green, blue, red and gold. What is its resistance value ? Also, write the colour band sequence for $390 \pm 20\% \Omega$.
3. What is the difference between active and passive components ? Name at least two in each category.
4. A Germanium diode carries a current of 1mA at room temperature when a forward bias of 0.15V is applied. Estimate the reverse saturation current at room temperature.
5. Derive the relationship between α and β of a transistor.
6. Draw the symbol and write the general specifications of the following :
 - a) Zener diode
 - b) NPN transistor.
7. What is the need for feedback in oscillators ? Explain the criteria for sustained oscillation.
8. Define ripple factor and write the values for half wave, center tapped and bridge rectifiers.
9. Draw the block diagram of a public address system.
10. Define the terms CMRR and slew rate. Give its value for an ideal op-amp.



11. Which are the universal gates ? Why are they called so ? Realize an AND gate using any one universal gate.
12. Draw the block diagram of a function generator and mark the output wave form of each block.
13. Why modulation is required in communication ?
14. Define percentage of modulation in AM and describe how the modulation index of AM wave evaluated from the waveform ?
15. Write radar range equation and specify the parameters used in the equation.
16. Why uplink frequency is different from downlink frequency in satellite communication ?
17. What is meant by frequency reuse in cellular communication ?
18. What are the major light sources used in optical fiber communication ?
19. Why FM preferred to AM for sound signal transmission in TV system ?
20. Describe the major features of HDTV system.

PART – B

Answer any 8 Questions. Each carrying five marks each.

21. What is the basic working principle of transformer ? List at least four different types of transformers and its applications.
22. Draw and explain the construction of electrolytic capacitor. Write its general specifications and applications.
23. Plot the forward and reverse characteristics of a PN diode and discuss it.
24. Compare the three transistor configurations and write the applications of each.
25. Discuss the working principle of solar cell and photo diode and differentiate them.
26. With neat circuit diagram and waveforms explain the working of a bridge rectifier with capacitor filter.



27. Discuss the need for biasing in amplifiers. Explain the functions of each component in RC coupled amplifier with relevant waveforms.
28. What is comparator ? Explain the working of an op-amp based comparator with circuit diagram and waveforms.
29. Explain the principle and working of a digital multimeter with block diagram and list the advantages over analog multimeter.
30. Draw the block diagram of a digital storage oscilloscope and specify the functions of each block.

PART – C

Answer **any 4** Questions. **Each** carrying **five** marks **each**.

31. Draw the block diagram of AM super heterodyne receiver and explain the functions of each block.
 32. Draw and explain the block diagram of pulsed radar.
 33. What are the satellite system link models ? Explain with neat diagram.
 34. What are the major network switching subsystems in GSM and explain the functions of each.
 35. With the help of block diagram, explain the working of an optical fiber communication system. What are the advantages ?
 36. Explain the operation of CCTV with block diagram and mention its applications.
-

10026

Reg. No.: _____

Name: _____

APJ ABDUL KALAM TECHNOLOGICAL UNIVERSITY

FIRST/SECOND SEMESTER B.TECH DEGREE EXAMINATION, JULY 2016

Course Code: EC100**Course Name: BASICS OF ELECTRONICS ENGINEERING**

Max. Marks: 100

Duration: 3 Hours

PART A*Answer ALL questions. Each question carries 2 marks*

1. For the samples given below, specify the nominal value, tolerance, maximum and minimum value.
 - a. A resistor coloured -yellow, violet, orange and gold
 - b. A capacitor with code- 104K
2. Differentiate active and passive components. Name at least two in each category.
3. Write any four applications of electronics in the field of automobile.
4. How a potential barrier is created in an open circuited PN junction diode?
5. Why Silicon diode is more popular than Germanium? Mention its applications and cut-in voltage.
6. Draw the symbol and write the general specifications of the following
 - a) Photo diode
 - b) PNP transistor
7. Define peak inverse voltage and write the values for Half wave, Centre tapped and Bridge rectifiers.
8. Draw the block diagram of a regulated power supply.
9. Compare positive and negative feedback.
10. What are the ideal characteristics of an op-amp?
11. What are the applications of CRO?
12. State and prove De-Morgan's theorem with truth table.
13. Modulation reduces the height of the antenna. Justify.
14. Define modulation index in AM and compute the percentage of modulation, when the maximum amplitude is 10V and minimum is 6V.
15. What is uplink and downlink in satellite communication? Which frequency is kept higher and why?
16. Write at least four important applications of RADARs.
17. What is hand-off in mobile communication and mention the types?

18. What are the major light detectors used in optical fiber communication system.
19. Why scanning and synchronizing is required in TV systems.
20. What is the need for cell splitting in cellular system?

PART B

Answer any 8 complete questions each having 5 marks

21. Discuss the construction, working and application of an electro-mechanical relay.
22. On what basis the capacitors are classified? List the different types of capacitors and discuss the operation of a variable capacitor?
23. Analyze the common emitter configuration of the transistor and derive the relation between α and β .
24. Draw and explain the experimental setup for obtaining the forward and reverse characteristics of a diode and plot the approximate graphs for silicon and germanium diodes.
25. Differentiate intrinsic and extrinsic semiconductors and discuss the formation of PN junction.
26. With neat circuit diagram and waveforms explain the working of a centre tapped full wave rectifier with capacitor filter.
27. Draw and explain the block diagram of a public address system.
28. What are oscillators? List the types and principle involved. Explain the working of any one oscillator with circuit diagram.
29. Draw the circuit and explain the working of a non-inverting amplifier with op-amp and obtain the expression for its closed loop gain.
30. Draw the block diagram of a digital storage oscilloscope and specify the functions of each block.

Answer any 4 complete questions each having 5 marks

31. Draw the block diagram of AM receiver and explain the functions of each block with waveforms.
32. What is GPS? Explain how GPS tracks the position?
33. Explain with a block schematic of the transponder used in satellite and list the band of frequencies used for different applications.
34. How does a GSM network connect people around? Describe the sequence of operations and components involved.
35. Explain optical communication with the help of block diagram and list the merits and demerits.
36. Describe a typical HDTV system with block diagram.

10030

Reg. No.: _____

Name: _____

APJ ABDUL KALAM TECHNOLOGICAL UNIVERSITY

FIRST/SECOND SEMESTER B.TECH DEGREE SPECIAL EXAMINATION, SEPT 2016

Course Code: EC100**Course Name: BASICS OF ELECTRONICS ENGINEERING**

Max. Marks: 100

Duration: 3 Hours

PART A*Answer ALL questions. Each question carries 2 marks*

1. Draw the symbol and write the general specifications of the following
 - a) Resistor
 - b) Loudspeaker
2. Write any four applications of electronics in the field of medical science.
3. What is inductance? Give at least two applications of inductor?
4. Differentiate between intrinsic and extrinsic semiconductors
5. What is base width modulation in a transistor?
6. Write the type number of the following
 - a) Medium power transistor
 - b) High frequency low power transistor
 - c) Power transistor
 - d) Silicon diode
7. What is the role of filters in rectifiers? List the different types of filters.
8. What is the need of biasing in transistor circuits?
9. What is the need for feedback in oscillators? Explain the criteria for sustained oscillation?
10. What are the advantages of DSO over analog CRO?
11. Write the truth table and symbol for EX-NOR gate and EX-OR gate.
12. Compare the characteristics of ideal and real op-amps.
13. What is the frequency deviation and modulation index for FM
14. Compare AM and FM.
15. What are the elements of a satellite transponder?
16. What are the merits and demerits of GEO satellites?
17. Distinguish between HLR and VLR in GSM.
18. Why the refractive index of core in optical fiber is greater than cladding.
19. Write the advantages and disadvantages of optical communication.
20. What are the merits of DTH over cable TV?

PART B

Answer any 8 complete questions each having 5 marks

21. Discuss the colour coding scheme of capacitors? Write the colour band sequence for the capacitance 470 pF?
22. With a neat figure, explain the construction of a carbon film resistor and mention its features.
23. Explain the working principle of LED? Explain the generation of different colours in LED with example.
24. Draw the output characteristics of a PNP transistor in CE mode and explain the three regions of operation.
25. Explain the principle of working of a Zener diode? Differentiate between Zener and Avalanche breakdown mechanisms?
26. Draw the circuit diagram of RC phase shift oscillator. How does the circuit satisfy the Barkhausen criteria?
27. Explain the operation of a bridge rectifier with circuit diagram and show that the ripple factor is 0.48.
28. Explain the operation of RC coupled amplifier with circuit diagram and frequency response.
29. State and explain De-Morgan's theorem.
Realize the Boolean expression $X=AB + \bar{B}C$ using any one of the universal gates and write the truth table.
30. Draw the block diagram of a function generator and specify the functions of each block.

Answer any 4 complete questions each having 5 marks

31. Draw the block diagram of FM receiver and explain the functions of each block with waveforms.
32. Draw the block diagram of a RADAR and describe the method for measuring the range of an object.
33. Briefly explain satellite communication system with a block diagram.
34. What is the principle of operation of GSM? What are the services offered by GSM?
35. Sketch the elements associated with an optical fiber communication system and describe the major light detectors.
36. With illustrations, explain the working of plasma display and mention its advantages and disadvantages.

Reg No.: _____

Name: _____

APJ ABDUL KALAM TECHNOLOGICAL UNIVERSITY
FIRST SEMESTER B.TECH DEGREE EXAMINATION, JANUARY 2017

Course code: **EC100**Course Name: **BASICS OF ELECTRONICS ENGINEERING**

Max. Marks: 100

Duration: 3 Hours

PART A

Answer ALL questions. Each carries 2 marks

1. Write any four applications of electronics in the field of communication.
2. Write down the capacitance values given in coded form as follows: (a) 104, (b) 2M2
3. What is the property of an inductor?
4. How a n-type semiconductor is formed?
5. Derive the relationship between α and β .
6. How does avalanche breakdown differ from zener breakdown?
7. What do you mean by ripple factor? Find the ripple factor for full wave rectifier.
8. Compare positive feedback and negative feedback.
9. Which are the important desirable characteristics of an amplifier?
10. Realize XOR gate using any one of the universal gates.
11. Differentiate between input offset current and input bias current and write down the nominal values of these currents for an ideal op-amp.
12. Draw the basic block diagram of an electronic measuring instrument and write the functions of each block.
13. What is the need for modulation?
14. Write any four advantages of FM.
15. What do you mean by geostationary satellite?
16. What is meant by superheterodyning?
17. Expand the following: SIM, MIN, MSC, PSTN related to cellular communication system.
18. What is meant by total internal reflection?
19. Write down the steps in the process of roaming.
20. Write the applications of CCTV.

PART B

Answer any 8 questions, each having 5 marks

21. With neat diagrams, explain the classification of fixed resistors.
22. Discuss the construction and operation of an electromechanical relay.
23. Explain the formation of potential barrier and establishment of current flow in forward biased p-n junction diode.
24. Differentiate between working principle of photo diode and LED.
25. How do you find the input and output static resistances (static and dynamic) of a BJT?
26. With neat circuit diagram, explain the working of a simple voltage regulator.
27. Write down the criterion for sustained oscillation. Explain the operation of RC phase shift oscillator.
28. Differentiate between inverting and non-inverting amplifiers and find out the closed loop gain for both.
29. Draw the block diagram of digital storage oscilloscope and specify the functions of each block.
30. Explain the generation of various waveforms in a function generator.

PART C

Answer any 4 questions, each having 5 marks

31. What is amplitude modulation? Derive an expression for total power transmitted in an AM system.
32. With the help of block diagram, explain the working of an FM super heterodyne receiver.
33. Which are the main elements of satellite communication system? Write the advantages and applications of satellite communication system.
34. What is the principle of cellular networks? Explain the concept of frequency reuse.
35. Sketch the functional blocks of an optical fiber communication system and describe the functions of each block. What are the advantages of optical communication?
36. Explain the operation of DTH system with block diagram.

Reg No.: _____

Name: _____

APJ ABDUL KALAM TECHNOLOGICAL UNIVERSITY
SECOND SEMESTER B.TECH DEGREE EXAMINATION, JUNE 2017

Course Code: **EC100**Course Name: **BASICS OF ELECTRONICS ENGINEERING**

Max. Marks:100

Duration: 3 Hours.

PART A*Answer ALL Questions. Each question carries 2 marks.*

1. Write any four applications of electronics.
2. Explain working principle of transformer. Name any two classification of transformer.
3. A carbon resistor has colour code violet, green and brown. Find the range of resistance value.
4. What is extrinsic semiconductor? Give four examples for pentavalent impurity and trivalent impurity.
5. Calculate the value of emitter current of a transistor in active region for which $\beta = 40$ and $I_B = 25\mu A$.
6. Draw the symbol of npn transistor. What are the typical doping concentrations and sizes of three regions of transistor?
7. Draw the block diagram of dc power supply and specify the functions of each block.
8. State Barkhausen's criterion for sustained oscillations.
9. Derive the expression for ripple factor of a half wave rectifier. What is its value?
10. Name any four parameters of operational amplifier. Give the values of these parameters for an ideal Op-Amp.
11. Draw the block diagram of Op-Amp and specify the function of each block.
12. Draw the symbol and truth table of XOR gate and XNOR gate.
13. Name and specify any four frequency bands used for satellite communication.
14. What are the needs for modulation?
15. The amplitude of carrier wave is 10V and frequency is 1KHz. Modulation index is 0.4. Calculate the total power transmitted of an AM wave.
16. Differentiate the concepts between uplink and downlink frequencies.
17. Write any four advantages of optical communication system over copper wire-based communication system.
18. What is frequency reuse?

19. Define total internal reflection. What is the approximate value of core and cladding diameter of OFC?
20. Name any four applications of CCTV.

PART B

Answer ANY 8 Questions. Each question carries 5 Marks.

21. With the help of necessary diagram, explain carbon composition resistor and carbon film resistor.
22. Explain the basic principles of contactors and relays with the help of neat schematics.
23. With the help of diagrams, explain the principle of operation of npn transistor. What is the current gain of common emitter transistor? What is the relationship between α and β ?
24. Explain the constructional details of LED and Solar Cell. Explain the working of each.
25. Briefly explain the working of Zener voltage regulator. Discuss the line regulation of a Zener voltage regulator.
26. Draw the circuit and explain the working of RC coupled common emitter amplifier. Plot its frequency response showing the cut off frequencies.
27. Explain the structure and operation of n type and p type semiconductor.
28. Define CMRR and slew rate of Op-Amp. Derive the expression for the gain of inverting and non-inverting amplifier using Op-Amp.
29. Draw the block diagram and explain the working of a function generator.
30. Construct XOR gate and XNOR gate using any one type of the universal gates only.

PART C

Answer ANY 4 Questions. Each question carries 5 Marks.

31. What is communication satellite and explain the operation of satellite communication system? Write any two application of satellite communication system.
32. What is modulation? Differentiate between amplitude modulation and frequency modulation. Define frequency deviation of FM.
33. Draw the block diagram of FM super heterodyne receiver and explain the working.
34. Explain the operation of cellular mobile communication system. Explain the steps involved in a typical call connection between two mobile users.
35. Draw the block diagram of optical communication system and explain. Write any two applications of optical communication system.
36. Draw the block diagram and explain the working of a cable TV system.

Total Pages: 2

Reg No.: _____

Name: _____

APJ ABDUL KALAM TECHNOLOGICAL UNIVERSITY
FIRST/SECOND SEMESTER B.TECH DEGREE EXAMINATION, JULY 2017

Course Code: **EC100**Course Name: **BASICS OF ELECTRONICS ENGINEERING**

Max. Marks: 100

Duration: 3 Hours

PART A*Answer all questions, each carries 2 marks.*

- 1 Write the resistance value for the given colour code orange, orange, yellow and gold? (2)
- 2 Briefly explain the working principle of transformer? (2)
- 3 What is the use of a relay? (2)
- 4 Differentiate between Zener breakdown and avalanche breakdown. (2)
- 5 What is meant by early effect in transistors? (2)
- 6 What is the basic principle behind the working of a photo diode? (2)
- 7 Draw the block diagram of public address system. (2)
- 8 State the working principle of an oscillator. (2)
- 9 Define (a) ripple factor (b) rectification efficiency. (2)
- 10 List the characteristics of an ideal op-amp. (2)
- 11 What are universal gates? Why are they called so? (2)
- 12 Draw the block diagram of a function generator? (2)
- 13 Explain the need for modulation? (2)
- 14 List out the advantages of geostationary satellites? (2)
- 15 Explain the concept of frequency reuse? (2)
- 16 Compare AM and FM. (2)
- 17 Mention the advantages of optical communication? (2)
- 18 Write the applications of CCTV. (2)
- 19 Write the principle of light transmission through optical fiber? (2)
- 20 Differentiate between single mode and multimode fibers? (2)

PART B*Answer any eight questions, each carries 5 marks.*

- 21 Explain the constructional details of: - (5)
 i) Carbon composition fixed resistors ii) Carbon potentiometers
- 22 Explain any two types of fixed capacitors with neat diagram. (5)
- 23 Sketch the input and output characteristics of common emitter transistor configuration and explain briefly? (5)
- 24 How a barrier potential is developed in a p-n junction diode? (5)
- 25 With a neat circuit diagram explain the working of an RC coupled amplifier. (5)
- 26 Discuss the working principle of bridge rectifier with relevant waveforms. (5)
- 27 With suitable circuit diagram explain the working of an inverting amplifier using op-amp. Also derive its voltage gain? (5)

- 28 Draw the block diagram of a DSO and explain its working? (5)
- 29 How a Zener diode functions as a voltage regulator explain? (5)
- 30 Explain how AND, OR and NOT function can be implemented using universal gates? (5)

PART C

Answer any four questions, each carries 5 marks.

- 31 With a neat block diagram explain the working of AM super heterodyne receiver? (5)
- 32 Explain the basic principle of cellular communication? (5)
- 33 a) Write the equation of an AM wave and explain each term? (3)
- b) Draw the frequency spectrum and find the associated bandwidth? (2)
- 34 Explain the working of an optical communication system? (5)
- 35 Explain the basic parts of a cable TV distribution system? (5)
- 36 Draw the schematic of DTH system and explain its working? (5)

Reg No.: _____

Name: _____

APJ ABDUL KALAM TECHNOLOGICAL UNIVERSITY
FIRST SEMESTER B.TECH DEGREE EXAMINATION, DECEMBER 2017

Course Code: EE100

Course Name: BASICS OF ELECTRICAL ENGINEERING

Max. Marks: 100

Duration: 3 Hours

PART A

Answer all questions, each carries 4 marks

- | | | Marks |
|----|---|-------|
| 1 | Differentiate between Constant voltage and constant current sources. | (4) |
| 2 | Compare electric and magnetic circuits. | (4) |
| 3 | Derive the expression for RMS value of a sinusoidal waveform. | (4) |
| 4 | Write the expression for three phase power in a delta connected system. | (4) |
| 5 | What are the advantages of a hydroelectric power plant? | (4) |
| 6 | Explain the working principle of a photovoltaic cell. | (4) |
| 7 | Explain the working principle of a DC motor. | (4) |
| 8 | Derive the emf equation of a transformer. | (4) |
| 9 | Define and write the expression for slip of a 3 phase induction motor. | (4) |
| 10 | Explain the working of a capacitor start single phase induction motor. | (4) |

PART B

MODULE (1-4)

Answer any four questions, each carries 10 marks

- 11 a) Solve the following circuit using mesh analysis and find i_x (5)

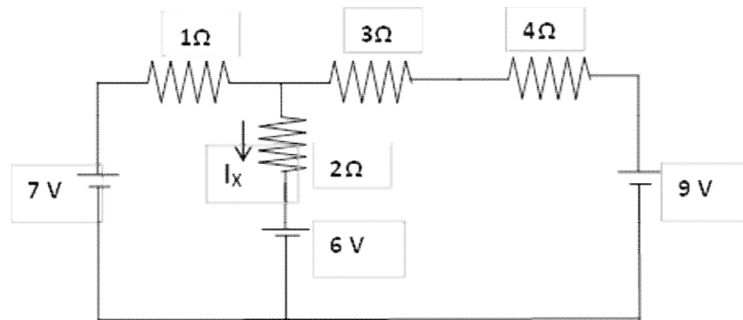

- b) With a sample circuit, explain the step by step procedure of nodal analysis. (5)
- 12 a) State and explain Faraday's laws of electromagnetic induction. (5)
- b) With suitable example, explain statically and dynamically induced emf. (5)
- 13 a) Define and obtain the expression for power factor, active power, reactive power and apparent power of a series RLC circuit. (5)
- b) A 50Ω resistor in series with $120\mu\text{F}$ capacitor is connected to 230V 50Hz supply. Find i) impedance ii) current iii) power factor iv) voltage across the resistor v) voltage across the capacitor. (5)
- 14 a) Explain the 2 wattmeter method of power measurement using the circuit arrangement. (5)
- b) A 3 phase 4 wire 400V system feeds three loads $10 - j8\Omega$ each connected in star. (5)

- Calculate the line currents in each phase.
- 15 With the help of a neat diagram, explain the working of a nuclear power plant. (10)
- 16 a) Explain the need for high voltage transmission. (5)
b) Explain the principle and operation of circuit breaker used in substation. (5)

MODULE 5

Answer any one full question

- 17 a) Explain different types of dc generators with suitable circuit diagrams and obtain voltage and current expressions of each. (7)
b) The maximum value of flux density in the core of a 250/3000V, 50Hz single phase transformer is 1.5Wb/m². If the emf /turn is 8V, determine i) primary and secondary number of turns ii) area of the core. (3)

OR

- 18 a) Draw and explain the constructional details of 3 phase transformers. (5)
b) A 220V DC shunt motor takes 30A at full load. Find the back emf developed if the armature and shunt field resistances are 0.5Ω and 110Ω respectively. (5)

MODULE 6

Answer any one full question

- 19 a) Draw and explain the constructional details of a 3 phase squirrel cage induction motor. (5)
b) A 6 pole 3phase induction motor operates from a supply whose frequency is 50Hz. Calculate (5)
i) The speed at which the magnetic field of the stator is rotating.
ii) The speed of the rotor when the slip is 0.03

OR

- 20 a) Explain why single phase induction motors are not self-starting. (5)
b) Draw and explain the constructional features of a three phase induction motor. (5)

Reg No.: _____

Name: _____

APJ ABDUL KALAM TECHNOLOGICAL UNIVERSITY
FIRST/SECOND SEMESTER B.TECH DEGREE EXAMINATION, APRIL 2018

Course Code: EC100

Course Name: BASICS OF ELECTRONICS ENGINEERING

Max. Marks: 100

Duration: 3 Hours

PART A

Answer all questions, each carries 5 marks.

Marks

- | | | |
|---|--|-----|
| 1 | Explain with diagram, the operation of an electromagnetic relay. | (5) |
| 2 | Draw and explain the forward and reverse characteristics of a PN junction diode using the diode equation. | (5) |
| 3 | Draw circuit diagram and explain how Zener diode can be used as a voltage regulator. | (5) |
| 4 | Draw the functional block diagram of operational amplifier and explain the functions of each block. | (5) |
| 5 | Distinguish between LEO, MEO and GEO satellites. | (5) |
| 6 | Explain the need for modulation. Write two drawbacks of frequency modulation compared to amplitude modulation. | (5) |
| 7 | Explain working of CCTV with block diagram. | (5) |
| 8 | With a block schematic explain functioning of a typical optical communication system. | (5) |

PART B

Answer six questions, one full question from each module and carries 10 marks.

Module I

- | | | |
|---|---|-----|
| 9 | a) With neat diagrams, explain construction of wire wound resistor and carbon composition resistors. | (5) |
| | b) A carbon resistor has colour code violet, grey, yellow and gold. Find the range of resistance value. | (5) |

OR

- | | | |
|----|--|------|
| 10 | Write the principle of working of transformer. Explain the losses that occur in a transformer. | (10) |
|----|--|------|

Module II

- | | | |
|----|--|-----|
| 11 | a) Explain the formation of depletion region in PN junction. | (5) |
| | b) Explain the principle of operation of LED. | (5) |

OR

- | | | |
|----|--|------|
| 12 | Describe the construction and operation of NPN transistor. | (10) |
|----|--|------|

Module III

- | | | |
|----|--|-----|
| 13 | a) With circuit diagram and waveforms, explain the working of centre tapped full wave rectifier. | (5) |
| | b) Draw the block diagram of a public address system and specify the functions of each block. | (5) |

OR

- 14 Explain with circuit diagram the working of common emitter amplifier. (10)

Module IV

- 15 a) Implement OR and AND gates using NOR gates only. (5)
b) Write the characteristics of an ideal opamp. Define the terms CMRR, slew rate as related to opamp. (5)

OR

- 16 Draw the block diagram of digital storage oscilloscope and explain the functions of each block. (10)

Module V

- 17 a) Define amplitude modulation. Derive an expression for representing amplitude modulated wave. (5)
b) With block diagram explain functions of a satellite transponder. (5)

OR

- 18 Explain working of super heterodyne receiver with block diagram. Write its advantages compared to tuned radio frequency receivers. (10)

Module VI

- 19 a) Explain how light is transmitted through optical fiber. Write two advantages of optical communication systems. (5)
b) With block diagram explain working of cable TV network. (5)

OR

- 20 Explain the concept of cells, frequency reuse and hand off in cellular mobile communication. (10)

Reg No.: _____

Name: _____

APJ ABDUL KALAM TECHNOLOGICAL UNIVERSITY
FIRST/SECOND SEMESTER B.TECH DEGREE EXAMINATION, JULY 2018

Course Code: EC100

Course Name: BASICS OF ELECTRONICS ENGINEERING

Max. Marks: 100

Duration: 3 Hours

PART A

Answer all questions, each carries 5 marks

Marks

- | | | |
|---|--|-----|
| 1 | Write four important milestone developments in the evolution of electronics and also give typical applications of electronics in different fields. | (5) |
| 2 | Differentiate between intrinsic and extrinsic semiconductors also plot the V-I characteristics of a silicon PN junction diode. | (5) |
| 3 | Draw and explain the basic components of a public address system. | (5) |
| 4 | What are universal gates? Why are they called so? List out the important properties of an ideal operational amplifier. | (5) |
| 5 | Define modulation. What are the different types of analog modulation schemes? Explain the need for modulation. | (5) |
| 6 | What is the super-heterodyne principle used in communication system. What are the typical frequencies used in AM and FM? | (5) |
| 7 | List out the major advantages of optical fiber communication system. | (5) |
| 8 | Explain the different components in CCTV system. | (5) |

PART B

Answer six questions, one full question from each module and carries 10 marks

Module I

- | | | |
|---|---|-----|
| 9 | a) Explain the principle of operation of transformer. What are the basic specifications of a transformer? | (5) |
| | b) What are the different types of capacitors based on the dielectric material used also explain the working principle of an electrolytic capacitor with suitable sketches. | (5) |

OR

- | | | |
|----|---|-----|
| 10 | a) With neat diagrams explain the principle and working of electromagnetic relays. | (5) |
| | b) What are the different classifications of resistors and also mention the importance of tolerance. Find the resistance value a resistor with the following colour code- Yellow, violet, gold and brown. | (5) |

Module II

- | | | |
|----|--|------|
| 11 | Explain the input and output characteristics of common emitter amplifier and also draw its frequency response. | (10) |
|----|--|------|

OR

12 Explain the working of photodiode and LED with suitable diagrams. (10)

Module III

13 a) Explain the concept of feedback mechanism, what are the different types? What are the typical use of each type? (5)

b) Define peak inverse voltage (PIV). Explain the working of a full wave bridge rectifier. (5)

OR

14 What is an oscillator? What are the different types? Explain the working of an RC phase shift oscillator. (10)

Module IV

15 a) What is the importance of an operational amplifier? Design a non-inverting amplifier with a gain of 11. (5)

b) Explain the working of a function generator. (5)

OR

16 With suitable diagrams explain the working of digital storage oscilloscope. List out its advantages over analog CRO. (10)

Module V

17 a) Draw the spectrum of AM signal with a sinusoidal input and also specify the differences in AM and FM with respect to: (5)

i) Modulation index ii) Bandwidth

b) Draw the block diagram of FM super-heterodyne receiver and explain its working. (5)

OR

18 a) What are the major applications of satellite communication? What are the different types of orbits used? Which band is used for satellite communication? (5)

b) What are geostationary satellites? Why are they called so? What are their advantages? (5)

Module VI

19 a) Draw the block diagram of optical communication explain? (5)

b) Draw the block diagram of DTH system and explain its operation. (5)

OR

20 a) Explain the concept of cells and frequency reuse in mobile communication. (5)

b) Explain the working of cable TV system. (5)

Reg No.: _____

Name: _____

APJ ABDUL KALAM TECHNOLOGICAL UNIVERSITY
FIRST SEMESTER B.TECH DEGREE EXAMINATION, DECEMBER 2018

Course Code: EC100

Course Name: BASICS OF ELECTRONICS ENGINEERING

Max. Marks: 100

Duration: 3 Hours

PART A

Answer all questions, each carries 5 marks.

Marks

- | | | |
|---|--|-----|
| 1 | Explain the different types of variable resistors? Mention their applications. | (5) |
| 2 | What is meant by intrinsic and extrinsic semiconductors? How a P-type semiconductor is formed? | (5) |
| 3 | Explain the working of Zener voltage regulator with a neat diagram. | (5) |
| 4 | Draw the functional block diagram of an operational amplifier. List the parameters of an ideal Op-amp | (5) |
| 5 | Write the expression of an AM and FM signal and explain the terms. | (5) |
| 6 | Explain how modulation reduces antenna height. | (5) |
| 7 | Discuss the major advantages of optical communication system. What are the sources and detectors used in optical fibre communication system? | (5) |
| 8 | What is meant by a DTH system? What are the main features of DTH? | (5) |

PART B

Answer six questions, one full question from each module and carries 10 marks.

Module 1

- | | | |
|---|--|-----|
| 9 | a) Write down the color code for a given resistor of 47-Kilo-ohms with a tolerance of 10%. | (4) |
| | b) Discuss on different types of transformers. | (6) |

OR

- | | | |
|----|---|-----|
| 10 | a) Give brief details of | (5) |
| | (i) Impact of electronics in industry | |
| | (ii) Medical electronics | |
| | b) Draw and explain the construction of a wet electrolytic capacitor. | (5) |

Module II

- | | | |
|----|--|-----|
| 11 | a) Sketch the input and output characteristics of common emitter transistor configuration and explain briefly. | (5) |
| | b) Derive the relation between α and β for a transistor. For an <i>npn</i> transistor, | (5) |

$\alpha=0.995$ and $I_E=10\text{m A}$. Find I_B and I_C ?

OR

- 12 Explain the working of LED and photodiode. Draw the necessary figures wherever applicable.. (10)

Module III

- 13 a) With necessary diagrams, explain the working of a centre-tapped full wave rectifier. (6)
- b) Compare the ripple factor and efficiency of half-wave, centre-tapped and bridge rectifiers (4)

OR

- 14 a) Write the conditions for sustained oscillations. (2)
- b) Draw the circuit diagram and explain the working of RC phase shift oscillator. Write the expression for its oscillation frequency. (8)

Module IV

- 15 Explain the generation of various waveforms in a function generator. (10)

OR

- 16 a) Draw the circuit of a non-inverting amplifier and derive the expression for its voltage gain (7)
- b) Design a non-inverting amplifier for a voltage gain of 11 (3)

Module V

- 17 a) What are the advantages and applications of satellite communication? (5)
- b) Explain how the geo-stationary satellite covers full earth? Why are they called so? (5)

OR

- 18 With a neat block diagram, explain the principle and working of superheterodyne receiver. (10)

Module VI

- 19 a) Describe step-index multimode, step-index single mode and graded index multimode fibres. (5)
- b) Explain cable TV network with its block diagram. (5)

OR

- 20 Draw and explain functional block diagram of cellular communication system. (10)

Reg No.: _____

Name: _____

APJ ABDUL KALAM TECHNOLOGICAL UNIVERSITY
FIRST/SECOND SEMESTER B.TECH DEGREE EXAMINATION, MAY 2019

Course Code: EC100

Course Name: BASICS OF ELECTRONICS ENGINEERING

Max. Marks: 100

Duration: 3 Hours

PART A

Answer all questions, each carries 5 marks.

Marks

- | | | |
|---|---|-----|
| 1 | Discuss any two applications of electronics from each of the following fields:
(a) industry and instrumentation.
(b) medicine | (5) |
| 2 | Draw the energy band diagram of conductors, semiconductors and insulators.
Also compare the energy band gap between them. | (5) |
| 3 | Draw the Block diagram of a public addressing system and explain. | (5) |
| 4 | Define the terms CMRR and slew rate. Give its value for an ideal op-amp. | (5) |
| 5 | Explain the concept of modulation and different modulation techniques. | (5) |
| 6 | What are geostationary satellites? Explain. | (5) |
| 7 | What is meant by
a) hand-off
b) Total internal reflection | (5) |
| 8 | List out the major advantages of optical communication system. What are the sources and detectors used in optical fibre communication system? | (5) |

PART B

Answer six questions, one full question from each module and carries 10 marks.

Module I

- | | | |
|---|--|-----|
| 9 | a) How an electromagnetic relay is different from contactors. | (4) |
| | b) Explain any <i>two</i> type of fixed resistors with necessary diagrams. | (6) |

OR

- | | | |
|----|---|-----|
| 10 | a) Draw and explain the construction of a wet electrolytic capacitor. | (5) |
| | b) What is the basic principle of transformer? Mention the important applications of transformer. | (5) |

Module II

- | | | |
|----|---|-----|
| 11 | a) Draw and explain the forward and reverse characteristics of a PN junction diode. | (5) |
| | b) Differentiate between avalanche and zener breakdown. | (5) |

OR

- 12 Explain the working of LED and photodiode. Draw the necessary figures (10)
wherever applicable..

Module 1II

- 13 Explain how transistor works as an amplifier. In an npn transistor $I_C = 9.9505\text{mA}$, $I_E = 10\text{mA}$, leakage current $I_{CBO} = 0.5\mu\text{A}$. Determine I_B, α and I_{CEO} . (10)

OR

- 14 With a neat circuit diagram and waveforms, explain the working of a full wave bridge rectifier with a capacitor filter. (10)

Module 1V

- 15 Draw circuit diagram and derive expressions for gain of inverting and non-inverting amplifier using Op-amp. (10)

OR

- 16 Draw the block diagram of Digital Storage Oscilloscope and explain the Working. (10)

Module V

- 17 a) Write down the expression for AM wave and explain. (4)
b) Explain the working of super heterodyne receiver. (6)

OR

- 18 Explain satellite communication with block diagram (10)

Module VI

- 19 a) With necessary diagram, explain how light is transmitted through an optical fibre? (5)
b) Explain each block of DTH system. (5)

OR

- 20 a) Explain the concept of cells and frequency reuse. (5)
b) Explain each block of CCTV system. (5)

Reg No.: _____

Name: _____

APJ ABDUL KALAM TECHNOLOGICAL UNIVERSITY
FIRST SEMESTER B.TECH DEGREE EXAMINATION(S), DECEMBER 2019

Course Code: EC100

Course Name: BASICS OF ELECTRONICS ENGINEERING

Max. Marks: 100

Duration: 3 Hours

PART A

Answer all questions, each carries 5 marks.

Marks

- | | | |
|---|--|-----|
| 1 | Discuss any <i>two</i> colour coding scheme of capacitors. Find the capacitance value for 2M2. | (5) |
| 2 | Explain doping concentration and size of three layers in a transistor with neat diagram. | (5) |
| 3 | Draw the diagram of an RC coupled CE amplifier and describe the role of the different capacitors. | (5) |
| 4 | Draw the block diagram of a function generator and specify the function of each block? | (5) |
| 5 | Compare AM and FM. | (5) |
| 6 | Define modulation index and write down the expression for modulation index and total power in AM signal. | (5) |
| 7 | Define critical angle and total internal reflection with diagrams. | (5) |
| 8 | Explain the basic block diagram of DTH system. | (5) |

PART B

Answer six questions, one full question from each module and carries 10 marks.

Module 1

- | | | |
|---|---|-----|
| 9 | a) What is a variable capacitor? Explain the construction of any 2 types of variable capacitors. | (6) |
| | b) The average value of a resistor required is 82k Ω . What will be the sequence of the colour band when tolerance would be 10%? | (4) |

OR

- | | | |
|----|--|-----|
| 10 | a) What are passive components? Mention at least three components with symbol. | (4) |
| | b) Explain with diagram, the operation of an electromagnetic relay | (6) |

Module II

- | | | |
|----|---|-----|
| 11 | a) Sketch the input and output characteristics of common emitter transistor configuration and explain briefly. | (5) |
| | b) Derive the relation between α and β for a transistor. For an npn transistor, $\alpha=0.995$ and $I_E=10\text{m A}$. Find I_B and I_C ? | (5) |

OR

- 12 Briefly explain
- i) LED (10)
 - ii) Photo diode
 - iii) Solar cell

Module III

- 13 a) Explain the working of a Bridge rectifier with relevant waveforms (7)
- b) What is PIV? What are its values for Half wave and Centre tapped Rectifiers? (3)

OR

- 14 What is a Barkhausen criterion? Explain the working of a RC phase shift Oscillator? (10)

Module IV

- 15 a) What are universal gates ? Why they are called so ? (4)
- b) Explain the working of digital multimeter with a block diagram (6)

OR

- 16 a) Draw and explain the functional block diagram of operational amplifier (6)
- b) Draw the circuit diagram and derive the gain of a non-inverting amplifier. (4)

Module V

- 17 a) Explain how the geo-stationary satellite covers full earth? Mention its applications. (6)
- b) List out the major merits of satellite communication. (4)

OR

- 18 a) What are the needs of modulation in a communication system. (6)
- b) Draw the spectrum of AM signal with a sinusoidal input (4)

Module VI

- 19 Explain the working of cable TV distribution system. (10)

OR

- 20 Explain optical fibre communication system with block diagram. What are the different types of optical fibre cables used in optical communication? (10)

Reg No.: _____

Name: _____

APJ ABDUL KALAM TECHNOLOGICAL UNIVERSITY
B.Tech degree examinations (S), September 2020 (S1/S2 - 2015 Scheme)

Course Code: EC100

Course Name: BASICS OF ELECTRONICS ENGINEERING

Max. Marks: 100

Duration: 3 Hours

PART A

Answer all questions, each carries 5 marks.

Marks

- | | | |
|---|--|-----|
| 1 | Briefly explain any five applications of electronics in medical field. | (5) |
| 2 | In what respect is an LED different from an ordinary PN junction diode? State any three applications of LEDs. | (5) |
| 3 | With necessary circuit diagram and waveforms, explain the working of a half wave Rectifier. | (5) |
| 4 | Define the terms input offset current, CMRR and slew rate of an Op-Amp. Write the ideal values of these parameters. | (5) |
| 5 | What is the function of mixer in AM superheterodyne receiver? What is the significance of IF frequency in AM receiver? | (5) |
| 6 | Define modulation. What are the needs for modulation? | (5) |
| 7 | Explain any one of the light sources used in optical fibre communication. | (5) |
| 8 | What is meant by frequency reuse in cellular system? | (5) |

PART B

Answer six questions, one full question from each module and carries 10 marks.

Module 1

- | | | |
|---|---|-----|
| 9 | a) Write notes on specifications of a capacitor. | (4) |
| | b) Explain the construction and working of relay. What are the different types of relays? | (6) |

OR

- | | | |
|----|---|-----|
| 10 | a) Explain the constructional details of | (6) |
| | i) Carbon composition fixed resistors ii) Carbon potentiometers | |
| | b) A carbon resistor has colour code violet, green and brown. Find the range of resistance value. | (4) |

Module II

- | | | |
|----|---|-----|
| 11 | a) Explain the formation of depletion layer in a pn junction diode. | (5) |
|----|---|-----|

- b) From the given parameters in a transistor circuit, compute the values of α , I_E and I_C : $\beta = 100$ and $I_B = 20\mu A$. (5)

OR

- 12 Draw the structure of a npn transistor showing the distribution of carries and explain its input and output characteristics in CE configuration. (10)

Module III

- 13 a) With necessary diagram explain the working of simple Zener voltage regulator. (5)
b) With the help of necessary diagram explain the working of RC coupled CE amplifier. (5)

OR

- 14 a) Compare the different types of feedback mechanisms? (4)
b) Why half-wave rectifiers are generally not used in power supply? With necessary diagram explain the working of centre-tap full wave rectifier. (6)

Module IV

- 15 Draw the block diagram of digital storage oscilloscope explain the functions of each block. (10)

OR

- 16 a) Draw and explain the functional block diagram of Operational amplifier. (5)
b) Draw the circuit diagram of a non-inverting amplifier with a voltage gain of 2. (5)

Module V

- 17 a) Explain satellite communication with block diagram. (7)
b) What are the advantages of geostationary satellites? (3)

OR

- 18 a) Compare AM and FM with minimum of five points. (5)
b) A 5 kHz audio signal is used to frequency-modulate a 100MHz carrier causing a frequency deviation of 20kHz. Determine (i) modulation index and (ii) Bandwidth of FM signal. (5)

Module VI

- 19 a) Draw the functional block diagram of cellular communication system. (5)
b) Explain the different components in CCTV system. (5)

OR

- 20 a) With a block schematic explain the operation of a DTH receiver. (5)
b) What is meant by critical angle? What is its significance in optical fiber communication? (5)
